

nobis
YOUR STOVE, OUR PASSION

TIME TO • 2023

YOUR NEXT STOVE

TIME TO NOBIS



È TEMPO DI NOBIS

Nobis è l'espressione di una tecnologia evoluta che ha a cuore il benessere delle persone.

È la stufa di nuova generazione con grandi performance, i più elevati standard di affidabilità e uno straordinario comfort, per un calore morbido e avvolgente. È silenziosa, è autonoma, è sicura, è rispettosa dell'ambiente, è certificata secondo i più alti standard richiesti dagli enti nazionali e internazionali.

IT'S TIME FOR NOBIS

Nobis is the embodiment of an advanced technology which has people's well-being at heart.

A cutting-edge, highly-performing stove ensuring the highest standards of reliability and extraordinary comfort, for a soft and enveloping feeling of warmth. It is silent, autonomous, safe, sustainable and certified in full compliance with the highest national and international standards.

Built with strong, long-lasting materials to ensure durability over time and reduce pellet and electricity consumption, the stove is equipped with an automatic cleaning system to minimize maintenance time.

**Nobis, the ultimate stove:
the stove of our time.**

Gestisce in modo automatico il ciclo di pulizia, riduce al minimo i tempi di manutenzione, ha componenti resistenti nel tempo, e consente un risparmio nei consumi di pellet ed elettricità.

**Nobis è la stufa moderna,
la stufa del nostro tempo.**

C'EST L'HEURE DE NOBIS

Nobis est l'expression d'une technologie de pointe, soucieuse du bien-être des personnes.

Notre poêle de nouvelle génération offre de grandes performances, les plus hauts standards de fiabilité, ainsi qu'un confort extraordinaire, pour profiter d'une chaleur douce et enveloppante. Il est silencieux, autonome, sûr, écologique et certifié selon les normes les plus élevées exigées par les organismes nationaux et internationaux. Il est capable de gérer indépendamment le cycle de nettoyage, réduisant au minimum les temps de maintenance. Ses composants résistent dans le temps et vous permettront d'économiser sur la consommation de granulés et d'électricité.

**Nobis est le poêle moderne,
le poêle de notre temps.**

TIME TO BE NOBIS

NOI SIAMO **NOBIS**

Un'azienda di persone non di numeri. Il significato di Nobis "con noi" esprime immediatamente la nostra filosofia.

NOI, una parola che include le persone che lavorano in azienda, i nostri clienti, i nostri centri assistenza e i nostri fornitori.

Il successo va raggiunto insieme, con la passione per il nostro lavoro che ogni giorno ci porta ad affrontare nuove sfide e nuovi obiettivi.

Gli obiettivi di Nobis sono ambiziosi e un team esperto rende ogni sfida possibile e ogni obiettivo raggiungibile.

Con Noi c'è il cliente che è il centro del nostro interesse, di tutte le nostre attività, decisioni e politiche aziendali. Il cliente è il primo riferimento per il nostro sviluppo futuro: ogni problema, tecnico o logistico, è un'opportunità di crescita aziendale e professionale.

Il cliente è il partner con cui affrontiamo il futuro, per offrire ogni giorno i prodotti con la tecnologia più avanzata nel settore, e per vincere le nuove sfide che il mercato globale oggi ci impone.

WE ARE **NOBIS**

A company made up of people, not numbers. The meaning of the word Nobis (from Latin "with us") is a direct expression of our philosophy.

Us: a word whose meaning encompasses not only all those people working at our company, but also our customers, service centers and suppliers. Success is to be achieved together with the passion we have for our work, which every day leads us on to face new challenges and new goals.

Nobis' goals are ambitious, though our expert team, with years of experience in the sector, makes every challenge possible and every goal achievable.

With 'us' is the customer, who is at the fulcrum of our interests, activities, decisions and company policies. The customer is the first point of reference for our development and our growth: every problem, technical or logistic, is an opportunity for business and professional growth.

Our customers are the partners we want to face the future with, to deliver cutting-edge products and win the new challenges set by today's global market.

NOUS SOMME **NOBIS**

Une entreprise de personnes, pas de chiffres. La signification de Nobis ("avec nous") exprime instantanément notre philosophie.

Derrière le mot NOUS, il y a les personnes qui travaillent dans l'entreprise mais également nos clients, nos centres de services et nos fournisseurs.

La clé du succès se fait avec la passion pour notre travail qui nous conduit chaque jour à relever de nouveaux défis et à atteindre de nouveaux objectifs.

Les objectifs de Nobis sont ambitieux. Pour cela, une équipe expérimentée depuis des années dans le secteur rend chaque défi possible et chaque objectif réalisable.

Nobis srl est une entreprise de personnes, d'experts dans le secteur, de personnes qui avec passion et amour se dédient à leur travail.

Avec nous, il y a le client qui est au centre de nos intérêts, de toutes nos activités, des décisions

et politiques de l'entreprise. Le client est la première référence de notre développement et de notre croissance. Tout problème, qu'il soit technique ou logistique, est une opportunité de croissance pour les entreprises et les professionnels.

Le client est le partenaire avec lequel Nobis srl entend faire face à l'avenir, aux nouveaux défis que le marché mondial nous impose aujourd'hui.



ASSEMBLAGGIO
ASSEMBLY
ASSEMBLAGE



SOFTWARE ELEMENTO
ELEMENTO
LOGICIEL ELEMENTO



DATABASE
DATABASE
BASE DE DONNÉES



PRIMA ACCENSIONE
FIRST IGNITION
PREMIER ALLUMAGE

TESTATA AL 100% IN 4 STEP

ASSEMBLAGGIO

I componenti vengono verificati all'arrivo in azienda e durante tutta la linea di montaggio, dal corpo stufa alle saldature, alla componentistica meccanica e ai cablaggi di motori e sonde. Viene inoltre effettuato il test di ermeticità di ogni singola stufa.

ATTIVAZIONE SOFTWARE

Sulla scheda elettronica e sul palmare vengono caricati i firmware di funzionamento e il software per il controllo della stufa. Attraverso una prova di funzionamento viene effettuato il controllo di tutta la componentistica da un punto di vista elettrico e meccanico.

DATABASE ENTRY

Ogni singolo componente viene associato alla matricola stufa e viene creata l'anagrafica prodotto. I dati sono caricati a sistema e permettono l'attivazione garanzia, il monitoraggio delle funzionalità della componentistica e l'assistenza sul prodotto..

PRIMA ACCENSIONE

Al termine della linea di produzione effettuiamo un test di prima accensione su ogni singola stufa. L'accensione dura circa 20 minuti, nei quali viene verificato il funzionamento dell'autopulizia, dei motori, i parametri di combustione e dei sistemi di sicurezza.



nobis
YOUR STOVE, OUR PASSION

100% **MADE IN ITALY**
TESTED
CERTIFIED

100% TESTED IN 4 STEPS

ASSEMBLY

All components are checked on arrival at our premises and throughout the assembly stage, from the stove body, welds and mechanical components up to motor and probe wiring. The stove air-tightness is also tested for hermetic installation.

SOFTWARE ACTIVATION

The product firmware and the stove management software are installed in the electronic board and in the remote control. A test run is carried out to check electrical mechanical functioning.

DATABASE ENTRY

Each component is paired with the stove serial number and product master data are created. Such data are uploaded into the system to activate the product warranty, and the function monitoring system, as well as enable the dedicated technical assistance service.

FIRST IGNITION

After production, we carry out a first-ignition test on each stove. Ignition lasts around 20 minutes, a time during which proper functioning of the stove self-cleaning system, motors, combustion parameters and safety systems are thoroughly checked.

100% TESTÉ EN 4 ÉTAPES

ASSEMBLAGE

Lorsque les composants arrivent dans l'entreprise et tout au long de la chaîne de montage : du corps du poêle aux soudures, des composants mécaniques au câblage des moteurs et des sondes, ils sont contrôlés. Le test d'étanchéité de chaque poêle individuel est également effectué.

ACTIVATION DU LOGICIEL

Le micrologiciel de fonctionnement et le logiciel de contrôle du poêle sont chargés sur la carte électronique et le télécommande. Grâce à un test fonctionnel, tous les composants sont vérifiés d'un point de vue électrique et mécanique.

BASE DE DONNÉES

Chaque composant individuel est associé au numéro de série du poêle, ainsi les données de base du produit sont créées. Les données sont chargées dans le système et permettent l'activation de la garantie, le suivi de la fonctionnalité des composants et l'assistance sur le produit.

PREMIER ALLUMAGE

A la fin de la chaîne de production, nous effectuons un premier test d'allumage sur chaque poêle. L'allumage dure environ 20 minutes, pendant lesquelles le fonctionnement de l'autonettoyage et des moteurs des paramètres de combustion et des systèmes de sécurité sont vérifiés.

LE BRASIER INÉGALÉ

L'innovant brasier Nobis garantit un nettoyage automatique continu, sans avoir besoin d'opérations manuelles. Il n'intervient pas à intervalles réguliers, comme la plupart des systèmes du marché,

mais seulement si vraiment nécessaire.

En seulement 15 minutes, le poêle s'éteint, se nettoie et se rallume de manière autonome, évitant le refroidissement des échangeurs.

Notre logiciel **Elemento** est capable de comprendre quand il est vraiment nécessaire d'exécuter le cycle de nettoyage

SCIVOLO CENERE
ASH SLIDE / DESCENTE CENDRES

CONCENTRATORE
CONCENTRATOR / CONCENTRATEUR

ARIA PRIMARIA
PRIMARY AIR / AIR PRIMAIRE

FONDELLO GIREVOLE AUTOPULENTE
SELF-CLEANING ROTATING PLATE /
FOND TOURNANT AUTONETTOYANT

CORPO IN GHISA IN FUSIONE UNICA
ONE-PIECE CAST IRON BODY /
CORPS EN FONTE D'UNE SEULE PIECE

ARIA SECONDARIA
SECONDARY AIR / AIR SECONDAIRE



TIME TO BE PERFECT



SCAN ME

IL BRACIERE SENZA RIVALI

L'innovativo braciere Nobis garantisce la pulizia automatica continua senza operazioni manuali e interviene non ad intervalli regolari - come la gran parte dei sistemi presenti sul mercato -

ma solamente in caso di reale necessità.

In soli 15 minuti la stufa si spegne, si pulisce e si riaccende in autonomia, evitando il raffreddamento degli scambiatori.

Il nostro software **Elemento** decide il momento più opportuno per effettuare il ciclo di pulizia, solo quando ce n'è veramente bisogno.

THE UNRIVALLED BRAZIER

Our innovative brazier ensures continuous automatic cleaning without need for manual operations. Moreover, it does not activate at regular intervals - as most systems on the market do - but only when

really necessary.

The stove switches off, cleans itself and switches back on again automatically in just 15 minutes, thus preventing heat exchangers from cooling down.

Our software **Elemento** will take care of choosing the best time to carry out cleaning, doing it only in real case of necessity.

Il nostro braciere è di serie su:

Our brazier is installed as standard on:

Notre brasier est standard sur:



STUFE ARIA
AIR STOVES / POÊLES À AIR



STUFE ACQUA
THERMOSTOVES / THERMOPOÊLES



STUFE IBRIDE
HYBRID STOVES / HYBRIDES



CAMINI
INSERTS / CHEMINÉES



CALDAIE
BOILERS / CHAUDIÈRES

TIME TO BE CLEAN



AUTOMATIC
CLEANING

IL FUOCO NUOVO, SEMPRE PULITO

L'innovativo sistema di pulizia automatica di Nobis garantisce un funzionamento continuo senza operazioni manuali fino a 40 giorni di utilizzo, intervenendo solamente in caso di reale necessità.

In soli 15 minuti la stufa si spegne, si pulisce e si riaccende in maniera completamente automatica evitando il raffreddamento degli scambiatori.

Elemento monitora il funzionamento e decide il momento corretto per effettuare il ciclo di pulizia.



SCAN ME

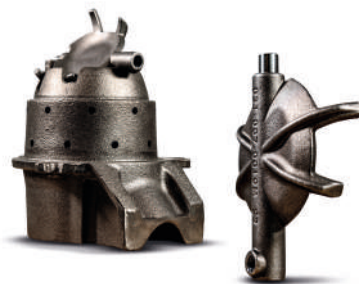

A NEW FIRE, ALWAYS CLEAN

Nobis' innovative automatic cleaning system guarantees continuous operation with no need for manual intervention, even after prolonged use, intervening only when really needed.

In just 15 minutes, the stove switches off, cleans itself and re-ignites automatically, thus preventing heat exchangers from cooling down.

Elemento monitors the operation and chooses the right time to perform the cleaning cycle.

UN FEU NOUVEAU, TOUJOURS PROPRE

Le système de nettoyage automatique innovant de Nobis garantit un fonctionnement continu sans opération manuelle, pendant longtemps. Il n'intervient pas à des intervalles programmés comme chez la plupart des systèmes disponibles sur le marché, mais uniquement en cas de réelle nécessité.

En seulement 15 minutes, le poêle s'éteint, se nettoie et se rallume automatiquement, évitant ainsi le refroidissement des échangeurs.

'Elemento' surveille le fonctionnement et décide le meilleur moment pour effectuer le cycle de nettoyage.

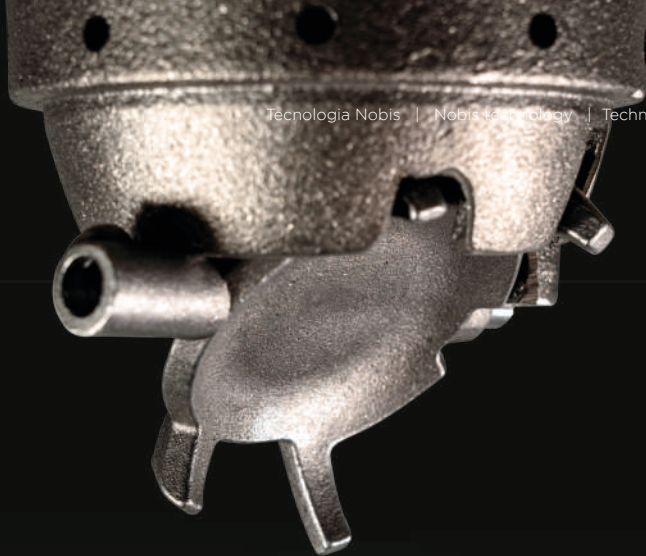

1

Accensione
Ignition
Allumage

2

Spegnimento
Switch-off
Arrêt

3

Pulizia
Cleaning
Nettoyage

4

Caricamento
Loading
Chargement

5

Riaccensione
Re-ignition
Rallumage

 **timeless**

LONG-LASTING MA-
TERIALS

SCAMBIATORI IN GHISA
CON EFFETTO VENTURI
CAST-IRON HEAT EXCHANGER (VENTURI EFFECT) /
ÉCHANGEURS EN FONTE AVEC EFFET VENTURI

CORPO A ALTO SPESSORE
HIGH-THICKNESS BODY / CORPS FORTE ÉPAISSEUR

SALDATURA ROBOTIZZATA
ROBOTIZED WELDING / SOUDURE ROBOTISÉ



TIME TO BE TIMELESS



MATERIALI SCELTI PER DURARE NEL TEMPO

Il corpo stufa è realizzato con materiali certificati ad alto spessore. La saldatura è completamente robotizzata, in modo da garantire una qualità e una durata costante nel tempo. Ogni corpo stufa viene controllato a fine linea tramite un test di ermeticità che garantisce la qualità della saldatura. Gli scambiatori in ghisa e il braciere ad alto spessore garantiscono una lunga durata nel tempo.

MATERIALS CHOSEN TO LAST OVER TIME

The stove body is made with high-thickness, certified materials. Welding is completely robotized, so as to guarantee quality over time. The hermetic seal of every stove body is checked at the end of the production line. Thick cast-iron heat exchangers and a high-thickness brazier ensure durability over time.

MATÉRIAUX CHOISIS POUR DURER DANS LE TEMPS

Le corps du poêle est fabriqué avec des matériaux certifiés de haute épaisseur. La soudure est entièrement robotisée, afin de garantir une qualité et une durée constantes dans le temps. Chaque corps de poêle est contrôlé en fin de ligne au moyen d'un test d'étanchéité qui garantit la qualité de la soudure. Les échangeurs en fonte et le brasier épais garantissent une longue durée de vie.

TIME TO CONNECT



CONTROLLO REMOTO REMOTE CONTROL / TÉLÉCOMMANDE

L'applicazione Nobis-Fi permette l'accensione, lo spegnimento e la regolazione della ventilazione anche quando non si è in casa tramite la rete wifi.

Nobis-Fi is an application which allows you to switch the product on and off and to adjust ventilation remotely, even when you are not at home, thanks to its WiFi network.

L'application Nobis-Fi vous permet d'allumer, d'éteindre et de régler la ventilation même lorsque vous n'êtes pas chez vous, grâce au réseau WiFi.

IMPOSTAZIONE CRONOTERMOSTATO / PROGRAMMABLE THERMOSTAT / RÉGLAGE DU CHRONOTHERMOSTAT

Personalizzare la stufa non è mai stato così semplice: in pochi secondi è possibile inserire fino a quattro programmazioni e gestire orari di accensione e spegnimento, temperatura, potenza e ventilazioni su uno o più giorni della settimana.

Customizing your stove has never been easier: enter up to four timer programs in just a few seconds and manage switch-on and switch-off hours, temperature, power and ventilation, for one or more days of the week.

Personnaliser le poêle n'a jamais été aussi simple : en quelques secondes, il est possible d'entrer jusqu'à quatre programmes et de gérer les temps de allumage et extinction, température, puissance et ventilation pour un ou plusieurs jours de la semaine.

GESTIONE MULTI-DISPOSITIVO / MULTI-DEVICE MANAGEMENT / GESTION MULTI-APPAREILS

Da un'unica applicazione è possibile gestire più dispositivi e programmare parametri e programmazioni in modo indipendente, via wi-fi o bluetooth.

Take advantage of WiFi or Bluetooth technology to manage several devices from one single application, to adjust parameters and set schedules independently.

À partir d'une seule application, il est possible de gérer plusieurs appareils et de programmer les paramètres et les horaires indépendamment, via Wi-Fi ou Bluetooth.



**CLEAN-GLASS
SYSTEM**



**IL FUOCO NUOVO,
VISIBILE**

Due condotti di aria indipendenti posizionati nella camera di combustione creano una membrana protettiva tra il vetro e la fiamma che permette di allontanare i residui di combustione dal vetro e lo mantiene sempre pulito, anche dopo molte ore di utilizzo, per una visione della fiamma sempre chiara nitida.

**THE NEW FIRE,
ALWAYS VISIBLE**

Two independent air ducts are installed in the combustion chamber to create a protective membrane between the glass and the flame. This helps keep combustion residue away from the glass. As a result, the doorpane remains clean even after prolonged use, so you can enjoy the view of the flame to the full.

**UN FEU NOUVEAU,
TOUJOURS VISIBLE**

Deux conduits d'air indépendants, positionnés dans la chambre de combustion, créent une membrane protectrice entre la vitre et la flamme. Cela permet d'éliminer les résidus de combustion du verre et de le garder toujours propre, même après de nombreuses heures d'utilisation, pour une vision toujours claire et nette de la flamme.

TIME TO HYBRID

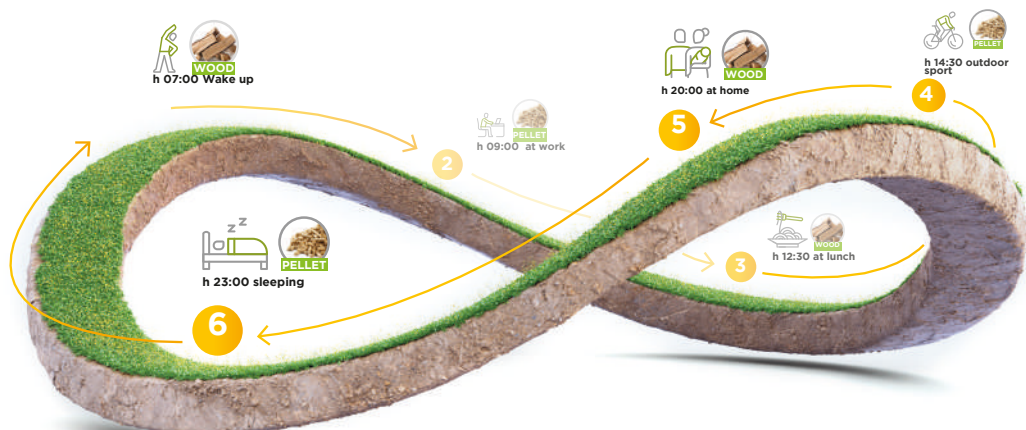

DOPPIA ALIMENTAZIONE, INFINITA LIBERTÀ

L'ibrido pellet-legna di Nobis combina i vantaggi di ciascuna alimentazione dandoti la libertà di scegliere come scaldare casa in ogni momento della tua giornata.

DOUBLE FUEL, INFINITE FREEDOM

Nobis hybrid stove combines the advantages of both pellet and wood fuelling, giving you the freedom to choose how to heat your home at any time of the day.



DOUBLE COMBUSTIBLE, LIBERTÉ INFINIE

Le poêle hybride Nobis combine les avantages des granulés et du bois, vous donnant la liberté de choisir comment chauffer votre maison à tout moment de la journée.



POT. 4,6 - 10,3 kW

UNICA 10



LEGNA / WOOD / BOIS



PELLET/ GRANULÉS

117
85
AB

Stufa ermetica 5 stelle con alimentazione ibrida pellet e legna.

Convezione naturale, ventilazione superiore completamente escludibile e canalizzazione posteriore con kit opzionale. Braciere autopulente con sistema automatico di controllo della combustione e dell'aria differenziato per combustibile.

Hermetic, pellet-wood hybrid stove.

Natural convection (it can be deactivated completely), top ventilation and rear canalization (available with optional kit). Self-cleaning brazier with automatic combustion/airflow control system optimized according to the fuel employed.

Poêle étanche hybride (granulés-bois).

Convection naturelle entièrement désactivable, ventilation supérieure et canalisation arrière (disponible avec kit en option). Brasier autonettoyant avec système de contrôle automatique de la combustion et du débit d'air, optimisé en fonction du combustible utilisé.



Beige



White



Carrara



Dark



Gray



Night

Dati tecnici
Technical data
Données techniques

PAG. 63

PELLET
18 kg

WEIGHT
250 kg

ENERGY
A+

D.M. 186
★★★★★

F.VERTE
7 ★

WI-FI
Included

REMOTE
Included

CANAL.
Single





POT. 4,1 - 8,5 kW | 4,1 - 10,4 kW

DTA

A8 V | A10 V

ROUND ROUND TOP ROUND TOP COAX

ROUND

ROUND TOP



Stufa a pellet a convezione naturale e ventilazione frontale, con canalizzazione posteriore singola con kit opzionale.

Natural-convection pellet stove equipped with front ventilation and single rear canalization (optional kit).

Poêle à granulés à convection naturelle équipé d'une ventilation frontale et canalisation arrière unique (kit en option).

Modulo Wi-Fi di serie e telecomando con funzione termostato ambiente. di serie.

Wi-Fi included and remote control with room thermostat function as standard.

Module Wi-Fi de série et télécommande avec fonction de thermostat d'ambiance en standard.



White

Bordeaux

Hazelnut

Black

Dati tecnici
Technical data
Données techniques

PAG. 63

PELLET
19 kg
Top 15 kg

WEIGHT
175 kg

ENERGY
A++

D.M. 186
★★★★★

F.VERTE
7 ★

WI-FI
Included

REMOTE
Included

CANAL.
Single





POT. 4,1 - 8,5 kW | 4,1 - 10,4 kW



A8 V | A10 V

ROUND GLASS ROUND TOP GLASS ROUND TOP GLASS COAX

ROUND ROUND TOP



Stufa a pellet a convezione naturale e ventilazione frontale, con canalizzazione posteriore singola con kit opzionale.

Natural-convection pellet stove equipped with front ventilation and single rear canalization (optional kit).

Poêle à granulés à convection naturelle équipé d'une ventilation frontale et canalisation arrière unique (kit en option).

Modulo Wi-Fi di serie e telecomando con funzione termostato ambiente. di serie.

Wi-Fi included and remote control with room thermostat function as standard.

Module Wi-Fi de série et télécommande avec fonction de thermostat d'ambiance en standard.



Carbon look



Wengé Noir



Silver



Black glass

Dati tecnici
Technical data
Données techniques

PAG. 64

PELLET
19 kg
Top 15 kg

WEIGHT
175 kg

ENERGY
A++

D.M. 186
★★★★★

F.VERTE
7 ★

WI-FI
Included

REMOTE
Included

CANAL.
Single





POT. 4,1 - 9,5 kW

DTA

A9 ZENITH



Stufa a pellet a convezione naturale e ventilazione frontale, con canalizzazione posteriore singola con kit opzionale.

Natural-convection pellet stove equipped with front ventilation and single rear canalization (optional kit).

Poêle à granulés à convection naturelle équipé d'une ventilation frontale et canalisation arrière unique (kit en option).

Modulo Wi-Fi di serie e telecomando con funzione termostato ambiente. di serie.

Wi-Fi included and remote control with room thermostat function as standard.

Module Wi-Fi de série et télécommande avec fonction de thermostat d'ambiance en standard.



White



Anthracite



Bordeaux



Bronze

Dati tecnici
Technical data
Données techniques

PAG. 64





POT. 4,1 - 10,4 kW

DTA

A10 ZENITH PLUS



Stufa a pellet a convezione naturale e ventilazione frontale, con canalizzazione posteriore singola con kit opzionale.

Natural-convection pellet stove equipped with front ventilation and single rear canalization (optional kit).

Poêle à granulés à convection naturelle équipé d'une ventilation frontale et canalisation arrière unique (kit en option).

Modulo Wi-Fi di serie e telecomando con funzione termostato ambiente. di serie.

Wi-Fi included and remote control with room thermostat function as standard.

Module Wi-Fi de série et télécommande avec fonction de thermostat d'ambiance en standard.



White



Anthracite



Bordeaux



Bronze

Dati tecnici
Technical data
Données techniques

PAG. 65

PELLET
19 kg

WEIGHT
163 kg

ENERGY
A++

D.M. 186
★★★★★

F.VERTE
7 ★

WI-FI
Included

REMOTE
Included

CANAL.
Single





POT. 4,1 - 8,5 kW



A8 V

QUADRA QUADRA TOP

QUADRA

QUADRA TOP



Stufa a pellet a convezione naturale e ventilazione frontale, con canalizzazione posteriore singola con kit opzionale.

Natural-convection pellet stove equipped with front ventilation and single rear canalization (optional kit).

Poêle à granulés à convection naturelle équipé d'une ventilation frontale et canalisation arrière unique (kit en option).

Modulo Wi-Fi di serie e telecomando con funzione termostato ambiente. di serie.

Wi-Fi included and remote control with room thermostat function as standard.

Module Wi-Fi de série et télécommande avec fonction de thermostat d'ambiance en standard.



White



Bordeaux



Bronze



Anthracite

Dati tecnici
Technical data
Données techniques

PAG. 65

PELLET
19 kg
Top 15 kg

WEIGHT
153 kg

ENERGY
A++

D.M. 186
★★★★★

F.VERTE
7 ★

WI-FI
Included

REMOTE
Included

CANAL.
Single





POT. 4,1 - 10,4 kW



A10

QUADRA PLUS QUADRA PLUS TOP

QUADRA

QUADRA TOP



Stufa a pellet a convezione naturale e ventilazione frontale, con motore centrifugo. Canalizzazione posteriore singola con kit opzionale.

Natural-convection pellet stove equipped with front ventilation and powerful fan. Single rear canalization (optional kit).

Poêle à granulés à convection naturelle éqipé d'une ventilation frontale avec ventilateur puissant. Canalisation arriére unique (kit en option).

Modulo Wi-Fi di serie e telecomando con funzione termostato ambiente. di serie.

Wi-Fi included and remote control with room thermostat function as standard.

Module Wi-Fi de série et télécommande avec fonction de thermostat d'ambiance en standard.

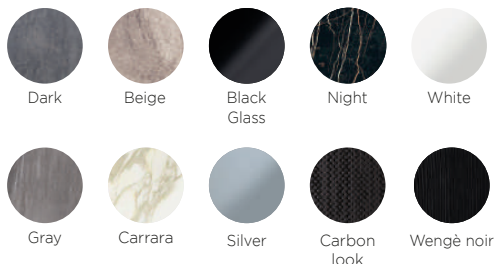

Dati tecnici
Technical data
Données techniques

PAG. 66

PELLET
19 kg
Top 15 kg

WEIGHT
153 kg

ENERGY
A++

D.M. 186
★★★★★

F.VERTE
7 ★

WI-FI
Included

REMOTE
Included

CANAL.
Single





POT. 4,1 - 9,5 kW

DTA

A9 CLASSIC



Stufa a pellet a convezione naturale e ventilazione superiore, con canalizzazione posteriore singola con kit opzionale.

Modulo Wi-Fi di serie e telecomando con funzione termostato ambiente di serie.

Natural-convection pellet stove equipped with front ventilation and single rear canalization (optional kit).

Wi-Fi included and remote control with room thermostat function as standard.

Poêle à granulés à convection naturelle équipé d'une ventilation supérieure et canalisation arrière unique (kit en option).

Module Wi-Fi de série et télécommande avec fonction de thermostat d'ambiance en standard.



White



Black



Bordeaux



Hazelnut

Dati tecnici
Technical data
Données techniques

PAG. 66





POT. 4,1 - 10,4 kW

DTA

A10 CLASSIC PLUS

118
—
53

Stufa a pellet a convezione naturale e ventilazione frontale con motore centrifugo. Canalizzazione posteriore singola con kit opzionale.

Natural-convection pellet stove equipped with front ventilation and powerful fan. Single rear canalization (optional kit).

Poêle à granulés à convection naturelle équipé d'une ventilation frontale avec ventilateur puissant. Canalisation arrière unique (kit en option).

Modulo Wi-Fi di serie e telecomando con funzione termostato ambiente. di serie.

Wi-Fi included and remote control with room thermostat function as standard.

Module Wi-Fi de série et télécommande avec fonction de thermostat d'ambiance en standard.



White

Black

Bordeaux

Hazelnut

Dati tecnici
Technical data
Données techniques

PAG. 67

PELLET
19 kg

WEIGHT
185 kg

ENERGY
A++

D.M. 186
★★★★★

F.VERTE
7 ★

WI-FI
Included

REMOTE
Included

CANAL.
Single





POT. 4,1 - 8,5 kW | 4,1 - 10,4 kW

A8 | A10 STYLE

STYLE



Stufa a pellet a convezione naturale e ventilazione frontale, con canalizzazione posteriore singola con kit opzionale.

Natural-convection pellet stove equipped with front ventilation and single rear canalization (optional kit).

Poêle à granulés à convection naturelle équipé d'une ventilation frontale et canalisation arrière unique (kit en option).

Modulo Wi-Fi di serie e telecomando con funzione termostato ambiente. di serie.

Wi-Fi included and remote control with room thermostat function as standard.

Module Wi-Fi de série et télécommande avec fonction de thermostat d'ambiance en standard.

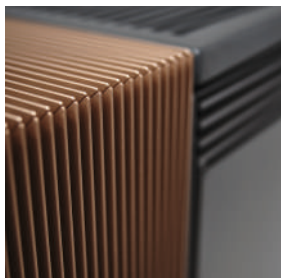

Dati tecnici
Technical data
Données techniques

PAG. 67





POT. 4,1 - 10,4 kW

DTA

A10 LIGHT

LIGHT



Stufa a pellet a convezione naturale con doppia canalizzazione e ventilazione frontale.

Pellet stove with natural convection, double canalization and front ventilation.

Poêle à granulés avec convection naturelle, canalisation double et ventilation frontale.

Modulo Wi-Fi di serie e telecomando con funzione termostato ambiente di serie.

Wi-Fi included and remote control with room thermostat function as standard.

Module Wi-Fi de série et télécommande avec fonction de thermostat d'ambiance en standard.



Night

White

Gray

Carrara

Dark

Beige

Black glass

Dati tecnici
Technical data
Données techniques

PAG. 67

PELLET
35 kg

WEIGHT
210 kg

ENERGY
A++

D.M. 186
★★★★★

F.VERTE
7 ★

WI-FI
Included

REMOTE
Included

CANAL.
Double





POT. 4,1 - 10,4 kW

DTA

A 10 LIGHT 2020

112
76

Stufa a pellet a convezione naturale doppia canalizzazione e ventilazione frontale.

Natural-convection pellet stove with double canalization and front ventilation.

Poêle à granulés avec convection naturelle, canalisation double et ventilation frontale.

Modulo Wi-Fi di serie e telecomando con funzione termostato ambiente. di serie.

Wi-Fi included and remote control with room thermostat function as standard.

Module Wi-Fi de série et télécommande avec fonction de thermostat d'ambiance en standard.

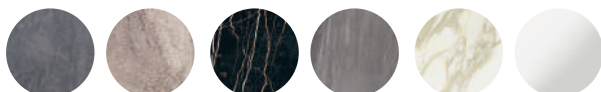

Dark

Beige

Night

Gray

Carrara

White

Dati tecnici
Technical data
Données techniques

PAG. 68

28

PELLET
35 kg

WEIGHT
210 kg

ENERGY
A++

D.M. 186
★★★★★

F.VERTE
7 ★

WI-FI
Included

REMOTE
Included

CANAL.
Double



POT. 3,8 - 7,7 kW | 3,8 - 10,5 kW

7|10 LISA

107
45 $\frac{5A}{}$

Stufa a pellet a ventilazione frontale con motore tangenziale. Canalizzazione posteriore singola con kit opzionale.

Modulo Wi-Fi fornito come optional e telecomando con funzione termostato ambiente di serie.

Pellet stove with front ventilation, single rear ducting front ventilation (optional kit) and powerful fan.

Wi-Fi as optional and remote control with room thermostat function as standard.

Poêle à granulés avec canalisation simple à l'arrière (kit optionnelle) et ventilateur puissant.

Module Wi-Fi optionnelle et télécommande avec fonction de thermostat d'ambiance en standard.



White

Black

Bordeaux

Dove gray

Dati tecnici
Technical data
Données techniques

PAG. 68

PELLET
16 kg

WEIGHT
120 kg

ENERGY
A+

D.M. 186
★★★★

F.VERTE
7 ★

WI-FI
Optional

REMOTE
Included

CANAL.
Single





POT. 5,2 - 12,5 kW

12 ELENA

120
71

Stufa a pellet a ventilazione frontale con motore tangenziale. Canalizzazione posteriore singola con kit opzionale.

Modulo Wi-Fi fornito come optional e telecomando con funzione termostato ambiente. di serie.

Pellet stove with front ventilation, single rear ducting front ventilation (optional kit) and powerful fan.

Wi-Fi as optional and remote control with room thermostat function as standard.

Poêle à granulés avec canalisation simple à l'arrière (kit optionnelle) et ventilateur puissant.

Module Wi-Fi optionnelle et télécommande avec fonction de thermostat d'ambiance en standard.



White

Black

Bordeaux

Dove gray

Dati tecnici
Technical data
Données techniques

PAG. 68





POT. 4,9 - 11,0 kW | 4,9 - 12,9 kW

DTA

A11 | A13

ROUND ROUND TOP ROUND TOP COAX

ROUND ROUND TOP



Stufa a pellet a convezione naturale e ventilazione frontale. Canalizzazione posteriore doppia o canalizzazione posteriore singola con kit opzionale.

Modulo Wi-Fi di serie e telecomando con funzione termostato ambiente. di serie.

Natural-convection pellet stove equipped with front ventilation. Double rear ducting or single rear ducting (optional kit).

Wi-Fi included and remote control with room thermostat function as standard.

Poêle à granulés à convection naturelle équipé d'une ventilation frontale. Canalisation double à l'arrière ou canalisation simple à l'arrière (kit en option).

Module Wi-Fi de série et télécommande avec fonction de thermostat d'ambiance en standard.



White

Bordeaux

Bronze

Anthracite

Dati tecnici
Technical data
Données techniques

PAG. 69

PELLET
20 kg
Top: 17 kg

WEIGHT
160 kg
Top: 183 kg

ENERGY
A+ A13
A++ A11

D.M. 186
★★★★★

F.VERTE
7 ★

WI-FI
Included

REMOTE
Included

CANAL.
Double
Top: Single



POT. 4,9 - 11,0 kW | 4,9 - 12,9 kW

DTA

A11 | A13

ROUND GLASS ROUND GLASS TOP ROUND GLASS TOP COAX

GLASS

GLASS TOP



Stufa a pellet a convezione naturale a ventilazione frontale. Canalizzazione posteriore doppia o singola con kit opzionale.

Modulo Wi-Fi di serie e telecomando con funzione termostato ambiente. di serie.

Natural-convection pellet stove with front ventilation, double rear ducting and front ventilation.

Wi-Fi included and remote control with room thermostat function as standard.

Poêle à granulés avec convection naturelle, canalisation double à l'arrière (kit optionnelle) et ventilateur frontale.

Module Wi-Fi de série et télécommande avec fonction de thermostat d'ambiance en standard.



Carbon look



Wengé Noir



Silver



Black glass

Dati tecnici
Technical data
Données techniques

PAG. 69

PELLET
17 kg
top 20

WEIGHT
160 kg
top 183

ENERGY
A+ A13
A++ A11

D.M. 186
★★★★★

F.VERTE
7 ★

WI-FI
Included

REMOTE
Included

CANAL.
Double
Top: Single



POT. 4,9 - 11,0 kW | 4,9 - 12,9 kW

DTA

A11 | A13

ZENITH

ZENITH



Stufa a pellet a convezione naturale e ventilazione frontale. Canalizzazione posteriore doppia o canalizzazione posteriore singola con kit opzionale.

Natural-convection pellet stove equipped with front ventilation. Double rear ducting or single rear ducting (optional kit).

Poêle à granulés à convection naturelle équipé d'une ventilation frontale. Canalisation double à l'arrière ou canalisation simple à l'arrière (kit en option).

Modulo Wi-Fi di serie e telecomando con funzione termostato ambiente. di serie.

Wi-Fi included and remote control with room thermostat function as standard.

Module Wi-Fi de série et télécommande avec fonction de thermostat d'ambiance en standard.



White



Anthracite



Bordeaux



Bronze

Dati tecnici
Technical data
Données techniques

PAG. 69

PELLET
22 kg

WEIGHT
183 kg

ENERGY
A+ → A13
A++ → A11

D.M. 186
★★★★★

F.VERTE
7 ★

WI-FI
Included

REMOTE
Included

CANAL.
Double



POT. 4,9 - 11,0 kW | 4,9 - 12,9 kW



A11 | A13

ZENITH PLUS



Stufa a pellet a convezione naturale a ventilazione frontale. Canalizzazione posteriore doppia o singola con kit opzionale.

Modulo Wi-Fi di serie e telecomando con funzione termostato ambiente. di serie.

Natural-convection pellet stove with front ventilation, double rear ducting and front ventilation.

Wi-Fi included and remote control with room thermostat function as standard.

Poêle à granulés avec convection naturelle, canalisation double à l'arrière (kit optionelle) et ventilateur frontale.

Module Wi-Fi de série et télécommande avec fonction de thermostat d'ambiance en standard.



White



Anthracite



Bordeaux



Bronze

Dati tecnici
Technical data
Données techniques

PAG. 70

PELLET
22 kg

WEIGHT
183 kg

ENERGY
A+ → A13
A++ → A11

D.M. 186
★★★★★

F.VERTE
7 ★

WI-FI
Included

REMOTE
Included

CANAL.
Double



POT. 4,9 - 9,9 kW

B10V

ULISSE

50
—
69 ⁴⁹

Inserto a pellet con ventilazione frontale.

Pellet fireplace with front ventilation.

Cheminée à granulés avec ventilation frontale.

Modulo Wi-Fi optional e telecomando con funzione termostato ambiente. di serie.

Wi-Fi optional and remote control with room thermostat function as standard.

Module Wi-Fi optionelle et télécommande avec fonction de thermostat d'ambiance en standard.

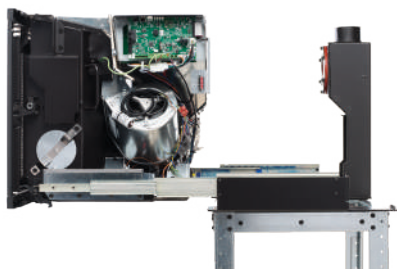

Dati tecnici
Technical data
Données techniques

PAG. 70

35

PELLET
14 kg

WEIGHT
95 kg

ENERGY
A+

D.M. 186
★★★★

F.VERTE
7 ★

WI-FI
Optional

REMOTE
Included



POT. 4,9 - 9,9 kW

B10C ULISSE



Inserto a pellet con ventilazione frontale, con canalizzazione singola.

Pellet insert canalized with front ventilation.

Cheminée à granules canalisée avec ventilation frontale.

Modulo Wi-Fi optional e telecomando con funzione termostato ambiente. di serie.

Wi-Fi as optional and remote control with room thermostat function as standard.

Module Wi-Fi optionnelle et télécommande avec fonction de thermostat d'ambiance en standard.



Dati tecnici
Technical data
Données techniques

PAG. 70





POT. 5,2 - 12,5 kW

B13

ULISSE

120
83

Inserto a pellet con ventilazione frontale e canalizzazione.

Pellet insert canalized with front ventilation.

Cheminée à granules canalisé avec ventilation frontale.

Modulo Wi-Fi optional e telecomando con funzione termostato ambiente di serie.

Wi-Fi optional and remote control with room thermostat function as standard.

Module Wi-Fi optionelle et télécommande avec fonction de thermostat d'ambiance en standard.



Carrara



Dark



Beige

Dati tecnici
Technical data
Données techniques

PAG. 71

PELLET
23 kg

WEIGHT
130 kg

ENERGY
A+

D.M. 186
★★★★

F.VERTE
7 ★

WI-FI
Included

REMOTE
Included

CANAL.
Single





POT. 8,8 - 18,9 kW | 8,8 - 21,2 kW POT. Δ 6,6 - 14,6 kW | 6,6 - 19,6 kW

HB 14 | 17

ULISSE HYDRO



Termocamino a pellet con ventilazione frontale.

Modulo Wi-Fi di serie e telecomando con funzione termostato ambiente. di serie.

Pellet hydrostove with front ventilation.

Wi-Fi included and remote control with room thermostat function as standard.

Thermocheminée à granulés avec ventilation frontale. Module Wi-Fi de série et télécommande avec fonction de thermostat d'ambiance en standard.



Wood Walnut



Wood White



Wood Black



Gray



Carrara



White

Dati tecnici
Technical data
Données techniques

PAG. 71



POT. 6,8 - 14,2 kW | 6,8 - 16,8 kW POT. Δ 4,8 - 10,0 kW | 4,8 - 12,0 kW

H10 | 12

SHAPE

113
—
53 60

Termostufa a pellet con ventilazione frontale.

Modulo Wi-Fi e telecomando con funzione termostato ambiente, di serie.

Pellet hydrostove with front ventilation.

Wi-Fi and remote control with room thermostat function as standard.

Thermopoêle à granulés avec ventilation frontale.
Module Wi-Fi et télécommande avec fonction de thermostat d'ambiance en standard.



White



Black



Bordeaux



Hazelnut

Dati tecnici
Technical data
Données techniques

PAG. 72

PELLET
20 kg

WEIGHT
165 kg

ENERGY
A++

D.M. 186
★★★★

F.VERTE
7 ★

WI-FI
Included

REMOTE
Included



POT. 6,8 - 14,2 kW | 6,8 - 16,8 kW POT. \diamond 4,8 - 10,0 kW | 4,8 - 12,0 kW

H 10 | 12

SHAPE GLASS

113
53 60

Termostufa a pellet con ventilazione frontale.

Modulo Wi-Fi di serie e telecomando con funzione termostato ambiente. di serie.

Pellet hydrostove with front ventilation.

Wi-Fi included and remote control with room thermostat function as standard.

Thermopoêle à granulés avec ventilation frontale.

Module Wi-Fi de série et télécommande avec fonction de thermostat d'ambiance en standard.



Carbon look



Wengé Noir



Silver



Black glass

Dati tecnici
Technical data
Données techniques

PAG. 72



POT. 8,8 - 19,8 kW | 8,8 - 21,2 kW POT. Ø 6,6 - 14,6 kW | 6,6 - 16,9 kW

H14 | 17

SHAPE STEEL

123
54 51

Termostufa a pellet con ventilazione frontale.

Pellet hydrostove with front ventilation.

Thermopoêle à granulés avec ventilation frontale.

Modulo Wi-Fi e telecomando con funzione termostato ambiente. di serie.

Pulizia automatica del fascio tubiero.

Wi-Fi and remote control with room thermostat function as standard.

Heat exchanger automatic cleaning.

Module Wi-Fi et télécommande avec fonction de thermostat d'ambiance en standard.

Nettoyage automatique de l'échangeur de chaleur.



White



Anthracite



Bordeaux



Bronze



Pulizia automatica del fascio tubiero

Heat exchanger automatic cleaning

Nettoyage automatique de l'échangeur de chaleur

Dati tecnici
Technical data
Données techniques

PAG. 73

PELLET
21 kg

WEIGHT
185 kg
220 kg

ENERGY
A++

D.M. 186
★★★★★

F.VERTE
7 ★

WI-FI
Included

REMOTE
Included



POT. 8,8 - 19,8 kW | 8,8 - 21,2 kW POT. Ø 6,6 - 14,6 kW | 6,6 - 16,9 kW

H14 | H17

SHAPE ROUND



Termostufa a pellet con ventilazione frontale. Modulo Wi-Fi di serie e telecomando con funzione termostato ambiente. di serie. Pulizia automatica del fascio tubiero.

Pellet hydrostove with front ventilation.

Wi-Fi included and remote control with room thermostat function as standard. Heat exchanger automatic cleaning.

Thermopoêle à granulés avec ventilation frontale. Module Wi-Fi de série et télécommande avec fonction de thermostat d'ambiance en standard. Nettoyage automatique de l'échangeur de chaleur.



White



Bordeaux



Bronze



Anthracite



Pulizia automatica del fascio tubiero

Heat exchanger automatic cleaning

Nettoyage automatique de l'échangeur de chaleur

Dati tecnici
Technical data
Données techniques

PAG. 73



POT. 8,5 - 21,6 kW

POT. Ø 6,4 - 17,0 kW

H17 LIGHT

$$\frac{112}{94} / 35$$

Termostufa a pellet con ventilazione frontale.

Pellet hydrostove with front ventilation.

Thermopoêle à granulés avec ventilation frontale.

Modulo Wi-Fi e telecomando con funzione termostato ambiente. di serie.

Pulizia automatica del fascio tubiero.

Wi-Fi and remote control with room thermostat function as standard.

Heat exchanger automatic cleaning.

Module Wi-Fi et télécommande avec fonction de thermostat d'ambiance en standard.

Nettoyage automatique de l'échangeur de chaleur.



Walnut wood



Black wood



White wood



Pulizia automatica del fascio tubiero

Heat exchanger automatic cleaning

Nettoyage automatique de l'échangeur de chaleur

Dati tecnici
Technical data
Données techniques

PAG. 73

PELLET
25 kg

WEIGHT
210 kg

ENERGY
A++

D.M. 186
★★★★

F.VERTE
7 ★

WI-FI
Included

REMOTE
Included



POT. 8,8 - 21,2 kW POT. Ø 6,6 - 16,9 kW

H17 SHAPE MAIOLICA

123
54 51

Termostufa a pellet con ventilazione frontale.

Modulo Wi-Fi di serie e telecomando con funzione termostato ambiente. di serie. Pulizia automatica del fascio tubiero.

Pellet hydrostove with front ventilation.

Wi-Fi included and remote control with room thermostat function as standard. Heat exchanger automatic cleaning.

Thermopoêle à granulés avec ventilation frontale.

Module Wi-Fi de série et télécommande avec fonction de thermostat d'ambiance en standard. Nettoyage automatique de l'échangeur de chaleur.



White



Black



Bordeaux



Hazelnut



Pulizia automatica del fascio tubiero

Heat exchanger automatic cleaning

Nettoyage automatique de l'échangeur de chaleur

Dati tecnici
Technical data
Données techniques

PAG. 74



POT. 11,0 - 23,8 kW

POT. Ø 8,4 - 20,1 kW

H20

SHAPE SHAPE STEEL

130
57 | 66

Termostufa a pellet con ventilazione frontale.

Pellet hydrostove with front ventilation.

Thermopoêle à granulés avec ventilation frontale.

Modulo Wi-Fi e telecomando con funzione termostato ambiente di serie.

Pulizia automatica del fascio tubiero.

Wi-Fi included and remote control with room thermostat function as standard.

Heat exchanger automatic cleaning.

Module Wi-Fi et télécommande avec fonction de thermostat d'ambiance en standard.

Nettoyage automatique de l'échangeur de chaleur.



White

Black

Bordeaux

Bronze



Pulizia automatica del fascio tubiero

Heat exchanger automatic cleaning

Nettoyage automatique de l'échangeur de chaleur

Dati tecnici
Technical data
Données techniques

PAG. 74

PELLET
37 kg

WEIGHT
260 kg

ENERGY
A++

D.M. 186
★★★★

F.VERTE
7★

WI-FI
Included

REMOTE
Included



POT. 11,0 - 30,0 kW

POT. Ø 8,4 - 25,1 kW

H25

SHAPE SHAPE STEEL

130
57 | 66

Termostufa a pellet con ventilazione frontale. Modulo Wi-Fi di serie e telecomando con funzione termostato ambiente. di serie. Pulizia automatica del fascio tubiero.

Pellet hydrostove with front ventilation.

Wi-Fi included and remote control with room thermostat function as standard. Heat exchanger automatic cleaning.

Thermopoêle à granulés avec ventilation frontale. Module Wi-Fi de série et télécommande avec fonction de thermostat d'ambiance en standard. Nettoyage automatique de l'échangeur de chaleur.



White

Anthracite

Bordeaux

Bronze



Pulizia automatica del fascio tubiero

Heat exchanger automatic cleaning

Nettoyage automatique de l'échangeur de chaleur

Dati tecnici
Technical data
Données techniques

PAG. 74



POT. 7,9 - 26,9 kW

POT. Ø7,2 - 24,7 kW

POLYGON 25

- Capacità acqua 80 Lt
Water Capacity 80l. / Capacité en eau 80l.
- Capacità serbatoio 75 Kg (standard in dotazione) o maggiorato 125 Kg
Standard tank capacity 75 Kg (it can be expanded up to 125Kg) / Capacité du réservoir standard 75 Kg (peut être étendu à 125Kg)
- Sistema automatico di regolazione della combustione
Automatic combustion system / Système de réglage automatique de la combustion
- Pulizia automatica del braciere
Automatic brazier cleaning / Nettoyage automatique du brasier
- Pulizia automatica del fascio tubiero tramite turbolatori
Automatic tube-bundle cleaning by turbulators / Nettoyage automatique du faisceau de turbulateurs
- Comodo compattatore delle ceneri
Practical ash compactor / Compacteur de cendres pratique
- Kit Wi-Fi di serie
Wi-Fi kit included / Kit Wi-Fi de série
- Kit sanitario opzionale
Optional DHW kit / Kit ECS en option
- Attacchi idraulici superiori
Upper hydraulic connections / Connexions hydrauliques supérieures
- Scarico fumi superiore o posteriore
Upper or rear exhaust outlet / Sortie des fumées supérieure ou arrière

140
105

Versione con serbatoio maggiorato da 125 kg
1280 x 1400 x 620 mm



Dati tecnici
Technical data
Données techniques

PAG. 75

PELLET
75 kg

WEIGHT
350 kg

ENERGY
A+

D.M. 186
★★★★★

F.VERTE
7★

WI-FI
Included



POT. 7,9 - 29,3 kW

POT. \varnothing 7,2 - 27 kW

POLYGON 28

- Capacità acqua 80 Lt
Water Capacity 80l. / Capacité en eau 80l.
- Capacità serbatoio 75 Kg (standard in dotazione) o maggiorato 125 Kg
Standard tank capacity 75 Kg (it can be expanded up to 125Kg) / Capacité du réservoir standard 75 Kg (peut être étendu à 125Kg)
- Sistema automatico di regolazione della combustione
Automatic combustion system / Système de réglage automatique de la combustion
- Pulizia automatica del braciere
Automatic brazier cleaning / Nettoyage automatique du brasier
- Pulizia automatica del fascio tubiero tramite turbolatori
Automatic tube-bundle cleaning by turbulators / Nettoyage automatique du faisceau de turbulateurs
- Comodo compattatore delle ceneri
Practical ash compactor / Compacteur de cendres pratique
- Kit Wi-Fi di serie
Wi-Fi kit included / Kit Wi-Fi de série
- Kit sanitario opzionale
Optional DHW kit / Kit ECS en option
- Attacchi idraulici superiori
Upper hydraulic connections / Connexions hydrauliques supérieures
- Scarico fumi superiore o posteriore
Upper or rear exhaust outlet / Sortie des fumées supérieure ou arrière

140
105

Versione con serbatoio maggiorato da 125 kg
1280 x 1400 x 620 mm



Dati tecnici
Technical data
Données techniques

PAG. 75



POT. 7,9 - 31,5 kW

POT. Δ 7,2 - 29,0 kW

POLYGON 32

- Capacità acqua 80 Lt
Water Capacity 80l. / Capacité en eau 80l.
- Capacità serbatoio 75 Kg (standard in dotazione) o maggiorato 125 Kg
Standard tank capacity 75 Kg (it can be expanded up to 125Kg) / Capacité du réservoir standard 75 Kg (peut être étendu à 125Kg)
- Sistema automatico di regolazione della combustione
Automatic combustion system / Système de réglage automatique de la combustion
- Pulizia automatica del braciere
Automatic brazier cleaning / Nettoyage automatique du brasier
- Pulizia automatica del fascio tubiero tramite turbolatori
Automatic tube-bundle cleaning by turbulators / Nettoyage automatique du faisceau de turbulateurs
- Comodo compattatore delle ceneri
Practical ash compactor / Compacteur de cendres pratique
- Kit Wi-Fi di serie
Wi-Fi kit included / Kit Wi-Fi de série
- Kit sanitario opzionale
Optional DHW kit / Kit ECS en option
- Attacchi idraulici superiori
Upper hydraulic connections / Connexions hydrauliques supérieures
- Scarico fumi superiore o posteriore
Upper or rear exhaust outlet / Sortie des fumées supérieure ou arrière



Versione con serbatoio maggiorato da 125 kg
1280 x 1400 x 620 mm



Dati tecnici
Technical data
Données techniques

PAG. 76

PELLET
125 kg

WEIGHT
350 kg

ENERGY
A+

D.M. 186
★★★★★

WI-FI
Included

TIME TO BE MAGIC

C'È MAGIA NEL FUOCO

Il profumo del ceppo, il crepitio del fuoco, il fascino incantatore della fiamma che si muove, la sensazione avvolgente e romantica del calore della brace, degli ambienti di una volta, quelli della nostra infanzia.

Tutto questo è la magia della fiamma a legna, del calore secondo la tradizione, del ritorno al passato per ridestare le nostre radici e prendersi il tempo di una piacevole pausa.

La nuova gamma a legna Nobis è pensata per amplificare la magia del fuoco a legna, e si presenta la camera di combustione in refrattario alta densità, in grado di ospitare ceppi fino a una lunghezza di 35cm per una fiamma ancora più profonda e naturale.

La gestione personalizzata dell'aria primaria e secondaria consente una combustione ottimale per avere una fiamma

luminosa e limpida.

La nuova gamma a legna è declinata in stufe con estetica e rivestimenti personalizzabili, e si arricchisce di accessori componibili su tutti i modelli: il cassetto portalegna, il forno e l'accumulo di 75 Kg a lento rilascio, per prolungare il tepore della stufa fino a diverse ore dopo il suo spegnimento.

THE MAGIC OF FIRE

Let yourself be carried away to the memories of yesteryear, and lose yourself in the scent of the logs, the crackling of the fire, the spellbinding charm of the dancing flame, the enveloping, romantic warmth of the embers.

The magic of firewood: travel back through time to rediscover our roots and let yourself sink into moments of pure relaxation. Our new wood-burning stoves, equipped with a high-density refractory combustion chamber, are designed to enhance the magic of a wood

fire and can contain logs up to 35 cm in length, for an even more intense and natural-looking flame.

Optimize combustion by adjusting both primary and secondary air and get a bright, vivid flame.

All the stoves in the range have customizable coverings and aesthetic features. Moreover, they are made available with modular accessories: from firewood drawer and oven, up to the refractory heat-storage system (75 kg) to keep on releasing heat even several hours after the stove is turned off.

LA MAGIE DU FEU

L'odeur des bûches, le crépitement du feu, le charme envoûtant de la flamme en mouvement, la sensation enveloppante et romantique de la chaleur des braises, des jours anciens : ceux de notre enfance.

Tout cela, c'est la magie du feu de bois, de la chaleur selon la tradition, du retour au passé pour réveiller nos racines et prendre le temps d'une pause agréable.

La nouvelle gamme Nobis est conçue pour amplifier la magie du feu de bois et dispose d'une chambre de combustion réfractaire à haute densité qui peut accueillir des bûches

jusqu'à 35 cm de long pour une flamme encore plus profonde et naturelle.

La gestion personnalisée de l'air primaire et secondaire permet une combustion optimale pour une flamme claire et brillante.

La nouvelle gamme de poêles à bois se décline en poêles à l'esthétique et au revêtement personnalisables et s'enrichit d'accessoires modulaires sur tous les modèles : tiroir à bois, four et accumulateur réfractaire de 75 kg pour prolonger la chaleur du poêle jusqu'à plusieurs heures après son extinction.

IL VETRO È TUTTA FIAMMA

VETRO A CORNICE RIDOTTA PER VISIONE
DELLA FIAMMA ANCORA PIÙ AMPIA

REDUCED BEZEL GLASS
FOR EVEN WIDER VIEW OF THE FLAME

VERRE À CADRE RÉDUIT
POUR UNE VUE DÉGAGÉE DE LA FLAMME

PIÙ SPAZIO PER IL TUO CALORE

Le stufe a legna Nobis sono dotate di una camera di combustioni ampia, che misura 32 x 35 x 45 cm e consente l'utilizzo di ceppi fino a 35 cm di lunghezza.

Il vetro a cornice ridotta permette una visione completa, per vivere l'esperienza di una fiamma ancora più corposa e luminosa.

La camera di combustione è realizzata in vermiculite ad alta densità e permette di raggiungere performance ambientali tra le migliori disponibili sul mercato, con basse emissioni e alti rendimenti.

MAKE SOME ROOM FOR YOUR WARMTH

Our wood-burning stoves are equipped with a large combustion chamber (32 x 35 x 45 cm) which can contain logs up to 35 cm in length.

The small-framed glass offers a perfect view of the interior to enjoy the flame to the full.

The highly-efficient, low-emission combustion chamber is made of high-density vermiculite and has allows to achieve one of the best environmental performance available on the market.



Dimensioni camera
di combustione

Dimensions of the
combustion chamber

Dimensions de la
chambre de combustion

PLUS D'ESPACE POUR VOTRE CHALEUR

Les poêles à bois Nobis possèdent une grande chambre de combustion, qui mesure 32 x 35 x 45 cm et permettent d'utiliser bûches d'une longueur maximale de 35 cm. Le cadre de la vitre d'épaisseur réduite permet de profiter d'une vue complète de la flamme, afin que vous puissiez jouir d'une flamme encore plus pleine et brillante. La chambre de combustion est constituée de vermiculite à haute densité et atteint des performances environnementales parmi les meilleures disponibles sur le marché, avec faibles émissions et rendement élevé.

NUOVI ACCESSORI COMPONIBILI

NEW, MODULAR ACCESSORIES
NOUVEAUX ACCESSOIRES MODULAIRES



CASSETTO O PORTALEGNA, FORNO, ACCUMULO A LENTO RILASCIO

Un pratico scomparto portalegna per ordinare i ceppi e dare alla casa un tocco di tradizione o un comodo cassetto con rivestimento coordinato alla stufa.

È possibile installare nella parte superiore un pratico forno, un metodo di cottura tradizione che esalta i profumi e i sapori della cucina italiana.

L'accumulo supplementare da 75 kg in refrattario può accumulare il calore quando la stufa è accesa, per rilasciarlo dopo lo spegnimento, mantenendo l'ambiente tiepido anche dopo diverse ore.

DRAWER OR LOG HOLDER, OVEN AND SLOW-RELEASE REFRACTORY ACCUMULATOR

A handy log storage compartment to give your home a traditional feel, or a convenient drawer with matching coating.

A practical oven can be installed at the top of the stove to cook your favorite dishes in the traditional way and enhance the flavor and aroma of your favorite recipes.

An additional 75 Kg heat accumulator can store the heat generated during operation, and release it after the stove is turned off, keeping the room warm even after several hours.

TIROIR OU PORTE-BÛCHES , FOUR , ACCUMULATEUR RÉFRACTAIRE À LIBÉRATION LENTE

Un compartiment pratique pour le stockage des bûches et pour donner à votre maison une touche traditionnelle, ou un tiroir pratique avec un revêtement assorti.

Un four pratique peut être installé dans la partie supérieure du poêle pour cuisiner vos plats préférés de manière traditionnelle et rehausser la saveur et l'arôme de vos recettes préférées.

L'accumulateur réfractaire supplémentaire de 75 kg peut emmagasiner de la chaleur lorsque le poêle est allumé et la restituer dans les heures qui suivent son arrêt, ce qui permet de garder la pièce chaude même après plusieurs heures.



GAMMA LEGNA 2023

FLAT 100*



Stufa a legna 5 stelle a convezione naturale con camera di combustione in vermiculite alta densità per ceppi fino a 35cm. Rivestimento in acciaio verniciato, controllo dell'aria primaria, secondaria e terziaria. Vetro a cornice ridotta per una visione della fiamma ancora più ampia.

5-star natural-convection wood stove equipped with high-density vermiculite combustion chamber for logs up to 35 cm. Painted steel coating. Primary, secondary and tertiary air control. Thinner glass frame for greater view of the flame.

Poêle à bois 7 étoiles Flamme Verte* à convection naturelle, avec chambre de combustion en vermiculite à haute densité pour bûches jusqu'à 35 cm. Revêtement en acier peint, contrôle de l'air primaire, secondaire et tertiaire. Vitre à cadre réduit pour une vue dégagée de la flamme.



Dati tecnici
Technical data
Données techniques

PAG. 76



GAMMA LEGNA 2023

FLAT 300* FLAT 330*

120
48
45

Stufa a legna 5 stelle a convezione naturale, ventilazione opzionale o canalizzazione singola posteriore opzionale. Camera di combustione in vermiculite alta densità per ceppi fino a 35cm di lunghezza, controllo dell'aria primaria, secondaria e terziaria. Vetro a cornice ridotta per una visione della fiamma ancora più ampia

5-star natural-convection wood stove, ventilation system (optional), or single rear canalization (optional). High-density vermiculite combustion chamber for logs long up to 35 cm. Primary, secondary and tertiary air control. Thinner glass frame for greater view of the flame.

Poêle à bois 7 étoiles Flamme Verte* avec convection naturelle, ventilation (en option) ou canalisation arrière simple (en option). Chambre de combustion en vermiculite à haute densité pour des bûches jusqu'à 35 cm de long. Contrôle de l'air primaire, secondaire et tertiaire. Vitre à cadre réduit pour une vision encore plus large de la flamme.

Flat 300

Flat 330



White

Anthracite

Bronze

White

Anthracite

Bronze

Dati tecnici
Technical data
Données techniques

PAG. 76

WEIGHT
165 kg

ENERGY
A+

D.M 186
★★★★★

F.VERTE
7★

*in corso di certificazione
certification pending
en attente de certification



GAMMA LEGNA 2023

FLAT 500* FLAT 550*

120
48

Stufa a legna 5 stelle a convezione naturale, ventilazione opzionale o canalizzazione singola posteriore opzionale. Rivestimento in pietra, camera di combustione in vermiculite alta densità per ceppi fino a 35cm di lunghezza, controllo dell'aria primaria, secondaria e terziaria. Vetro a cornice ridotta per una visione della fiamma ancora più ampia

5-star natural-convection wood stove, ventilation system (optional), or single rear canalization (optional). Stone coating, high-density vermiculite combustion chamber for logs long up to 35 cm. Primary, secondary and tertiary air control. Thinner glass frame for greater view of the flame.

Poêle à bois 7 étoiles Flamme Verte* avec convection naturelle, ventilation (en option) ou canalisation arrière simple (en option). Revêtement en pierre, chambre de combustion en vermiculite à haute densité pour des bûches jusqu'à 35 cm de long. Contrôle de l'air primaire, secondaire et tertiaire. Vitre à cadre réduit pour une vision encore plus large de la flamme.

Flat 500

Flat 550



Gray

Black

Travertino

Gray

Black

Travertino

Dati tecnici
Technical data
Données techniques

PAG. 76



GAMMA LEGNA 2023

FLAT 700* FLAT 770*

120
—
48

AS

Stufa a legna 5 stelle a convezione naturale, ventilazione opzionale o canalizzazione singola posteriore opzionale. Rivestimento in pietra, camera di combustione in vermiculite alta densità per ceppi fino a 35cm di lunghezza, controllo dell'aria primaria, secondaria e terziaria. Vetro a cornice ridotta per una visione della fiamma ancora più ampia

5-star natural-convection wood stove, ventilation system (optional), or single rear canalization (optional). Stone coating, high-density vermiculite combustion chamber for logs long up to 35 cm. Primary, secondary and tertiary air control. Thinner glass frame for greater view of the flame.

Poêle à bois 7 étoiles Flamme Verte* avec convection naturelle, ventilation (en option) ou canalisation arrière simple (en option). Revêtement en pierre, chambre de combustion en vermiculite à haute densité pour des bûches jusqu'à 35 cm de long. Contrôle de l'air primaire, secondaire et tertiaire. Vitre à cadre réduit pour une vision encore plus large de la flamme.

Flat 700

Flat 770



Grey

Black

Travertino

Gray

Black

Travertino

Dati tecnici
Technical data
Données techniques

PAG. 77

WEIGHT
165 kg

ENERGY
A+

D.M 186
★★★★★

F.VERTE
7★

*in corso di certificazione
certification pending
en attente de certification



GAMMA LEGNA 2023

ZENITH 400* ZENITH 440*

120
53

Stufa a legna 5 stelle a convezione naturale, ventilazione opzionale o canalizzazione singola posteriore opzionale. Camera di combustione in vermiculite alta densità per ceppi fino a 35cm di lunghezza, controllo dell'aria primaria, secondaria e terziaria. Vetro a cornice ridotta per una visione della fiamma ancora più ampia.

5-star natural-convection wood stove, ventilation system (optional), or single rear canalization (optional). High-density vermiculite combustion chamber for logs long up to 35 cm. Primary, secondary and tertiary air control. Thinner glass frame for greater view of the flame.

Poêle à bois 7 étoiles Flamme Verte* avec convection naturelle, ventilation (en option) ou canalisation arrière simple (en option). Chambre de combustion en vermiculite à haute densité pour des bûches jusqu'à 35 cm de long. Contrôle de l'air primaire, secondaire et tertiaire. Vitre à cadre réduit pour une vision encore plus large de la flamme.

Zenith 400

Zenith 440



Dati tecnici
Technical data
Données techniques

PAG. 77

58

WEIGHT
165 kg

ENERGY
A+

D.M. 186
★★★★★

F.VERTE
7★

*in corso di certificazione
certification pending
en attente de certification



GAMMA LEGNA 2023

ZENITH 600* ZENITH 660*

120
53

Stufa a legna 5 stelle a convezione naturale, ventilazione opzionale o canalizzazione singola posteriore opzionale. Camera di combustione in vermiculite alta densità per ceppi fino a 35cm di lunghezza, controllo dell'aria primaria, secondaria e terziaria. Vetro a cornice ridotta per una visione della fiamma ancora più ampia.

5-star natural-convection wood stove, ventilation system (optional), or single rear canalization (optional). High-density vermiculite combustion chamber for logs long up to 35 cm. Primary, secondary and tertiary air control. Thinner glass frame for greater view of the flame.

Poêle à bois 7 étoiles Flamme Verte* avec convection naturelle, ventilation (en option) ou canalisation arrière simple (en option). Chambre de combustion en vermiculite à haute densité pour des bûches jusqu'à 35 cm de long. Contrôle de l'air primaire, secondaire et tertiaire. Vitre à cadre réduit pour une vision encore plus large de la flamme.

Zenith 600



White



Black



Bronze

Zenith 660



White



Black



Bronze

Dati tecnici
Technical data
Données techniques

PAG. 78

WEIGHT
165 kg

ENERGY
A+

D.M 186
★★★★★

F.VERTE
7★

*in corso di certificazione
certification pending
en attente de certification



GAMMA LEGNA 2023

ZENITH 800* ZENITH 880*



Stufa a legna 5 stelle a convezione naturale, ventilazione opzionale o canalizzazione singola posteriore opzionale. Rivestimento in vetro, camera di combustione in vermiculite alta densità per ceppi fino a 35cm di lunghezza, controllo dell'aria primaria, secondaria e terziaria. Vetro a cornice ridotta per una visione della fiamma ancora più ampia.

5-star natural-convection wood stove, ventilation system (optional), or single rear canalization (optional). Glass coating, high-density vermiculite combustion chamber for logs long up to 35 cm. Primary, secondary and tertiary air control. Thinner glass frame for greater view of the flame.

Poêle à bois 7 étoiles Flamme Verte* avec convection naturelle, ventilation (en option) ou canalisation arrière simple (en option). Revêtement en verre, chambre de combustion en vermiculite à haute densité pour des bûches jusqu'à 35 cm de long. Contrôle de l'air primaire, secondaire et tertiaire. Vitre à cadre réduit pour une vision encore plus large de la flamme.

Zenith 800

Zenith 880



Carbon look



Black



Wengé



Carbon look



Black



Wengé

Dati tecnici
Technical data
Données techniques

PAG. 78

WEIGHT
165 kg

ENERGY
A+

D.M. 186
★★★★★

F.VERTE
7★

*in corso di certificazione
certification pending
en attente de certification



GAMMA LEGNA 2023

CLASSIC 200* CLASSIC 220*

120
53

Stufa a legna 5 stelle a convezione naturale, ventilazione opzionale o canalizzazione singola posteriore opzionale. Rivestimento in maiolica, camera di combustione in vermiculite alta densità per ceppi fino a 35cm di lunghezza, controllo dell'aria primaria, secondaria e terziaria. Vetro a cornice ridotta per una visione della fiamma ancora più ampia.

5-star natural-convection wood stove, ventilation system (optional), or single rear canalization (optional). Ceramic coating, high-density vermiculite combustion chamber for logs long up to 35 cm. Primary, secondary and tertiary air control. Thinner glass frame for greater view of the flame.

Poêle à bois 7 étoiles Flamme Verte* avec convection naturelle, ventilation (en option) ou canalisation arrière simple (en option). Revêtement en majolica, chambre de combustion en vermiculite à haute densité pour des bûches jusqu'à 35 cm de long. Contrôle de l'air primaire, secondaire et tertiaire. Vitre à cadre réduit pour une vision encore plus large de la flamme.

Classic 200



White



Bordeaux



Gray

Classic 220



White



Bordeaux



Gray

Dati tecnici
Technical data
Données techniques

PAG. 78

WEIGHT
165 kg

ENERGY
A+

D.M 186
★★★★★

F.VERTE
7★

*in corso di certificazione
certification pending
en attente de certification



DATI TECNICI

TECHNICAL DATA | DONNÉES TECHNIQUE

UNICA 10

85 x 48 x 117 cm

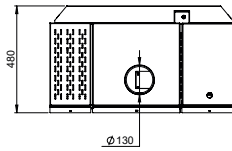
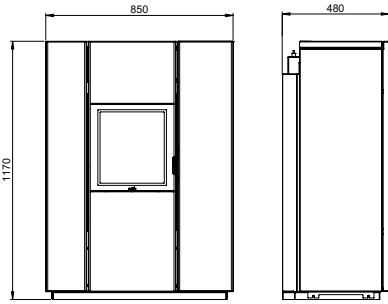

A9
VC

Potenza termica nom.		
Nominal heat output	kW min	4,2
Puissance thermique nom.	max	9,3
Consumo orario pellet		
Pellet consumption	kg/h min	0,9
Consommation granulés	max	2,2
Rendimento		
Yield	%	90
Rendement		
Capacità serbatoio		
Tank capacity	kg	18
Capacité du réservoir		
Tubo uscita fumi		
Smoke outlet pipe	Ø	130
Tuyau de sortie des fumées	mm	
Autonomia		
Burn time	h min	8
Autonomie	max	20
Potenza elettrica inst.		
Installed power	W	55
Puissance électrique		95
Peso netto		
Net weight	kg	250
Poids net		

A8 | A10 ROUND

53 x 54 x 113 cm

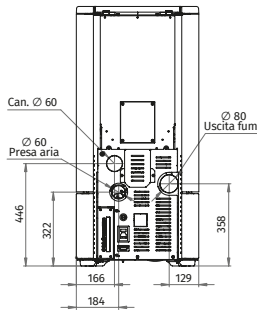
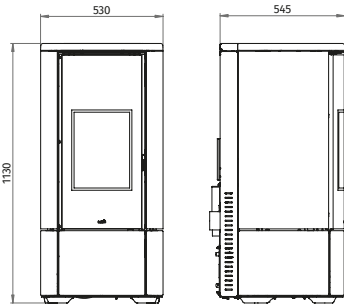

A8 A10
VC VC

Potenza termica nom.			
Nominal heat output	kW min	3,8	3,8
Puissance thermique nom.	max	7,8	9,5
Consumo orario pellet			
Pellet consumption	kg/h min	0,8	0,8
Consommation granulés	max	1,7	2,2
Rendimento			
Yield	%	92,1	90,9
Rendement			
Capacità serbatoio			
Tank capacity	kg	19	19
Capacité du réservoir			
Tubo uscita fumi			
Smoke outlet pipe	Ø	80	80
Tuyau de sortie des fumées	mm		
Autonomia			
Burn time	h min	11	9
Autonomie	max	22	22
Potenza elettrica inst.			
Installed power	W	15	15
Puissance électrique		60	60
Peso netto			
Net weight	kg	175	175
Poids net			

A8 | A10 ROUND TOP

53 x 58 x 113 cm

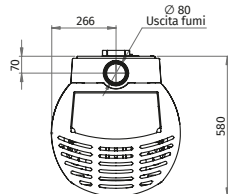
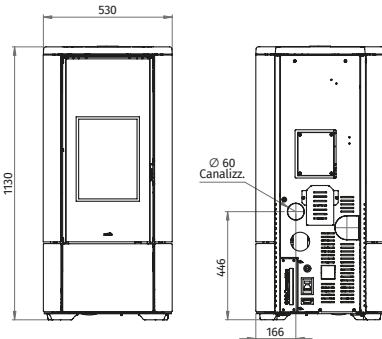

A8 A10
VC VC

Potenza termica nom.			
Nominal heat output	kW min	3,8	3,8
Puissance thermique nom.	max	7,8	9,5
Consumo orario pellet			
Pellet consumption	kg/h min	0,8	0,8
Consommation granulés	max	1,7	2,2
Rendimento			
Yield	%	92,1	90,9
Rendement			
Capacità serbatoio			
Tank capacity	kg	15	15
Capacité du réservoir			
Tubo uscita fumi			
Smoke outlet pipe	Ø	80	80
Tuyau de sortie des fumées	mm		
Autonomia			
Burn time	h min	9	7
Autonomie	max	17	17
Potenza elettrica inst.			
Installed power	W	15	15
Puissance électrique		60	60
Peso netto			
Net weight	kg	175	175
Poids net			

A8 | A10 ROUND GLASS

53 x 54 x 113 cm

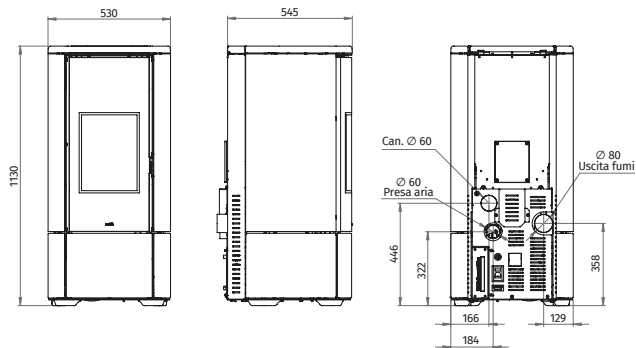

			A8	A10
			VC	VC
Potenza termica nom.	Nominal heat output	kW	min 3,8	3,8
	Puissance thermique nom.		max 7,8	9,5
Consumo orario pellet	Pellet consumption	kg/h	min 0,8	0,8
	Consommation granulés		max 1,7	2,2
Rendimento	Yield	%	92,1	90,9
	Rendement			
Capacità serbatoio	Tank capacity	kg	19	19
	Capacité du réservoir			
Tubo uscita fumi	Smoke outlet pipe	Ø mm	80	80
	Tuyau de sortie des fumées			
Autonomia	Burn time	h	min 11	9
	Autonomie		max 22	22
Potenza elettrica inst.	Installed power	W	15	15
	Puissance électrique		60	60
Peso netto	Net weight	kg	175	175
	Poids net			

A8 | A10 ROUND TOP GLASS

53 x 58 x 113 cm

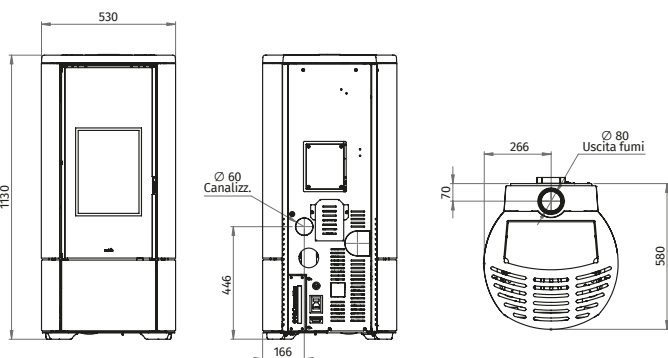

			A8	A10
			VC	VC
Potenza termica nom.	Nominal heat output	kW	min 3,8	3,8
	Puissance thermique nom.		max 7,8	9,5
Consumo orario pellet	Pellet consumption	kg/h	min 0,8	0,8
	Consommation granulés		max 1,7	2,2
Rendimento	Yield	%	92,1	90,9
	Rendement			
Capacità serbatoio	Tank capacity	kg	15	15
	Capacité du réservoir			
Tubo uscita fumi	Smoke outlet pipe	Ø mm	80	80
	Tuyau de sortie des fumées			
Autonomia	Burn time	h	min 9	7
	Autonomie		max 17	17
Potenza elettrica inst.	Installed power	W	15	15
	Puissance électrique		60	60
Peso netto	Net weight	kg	175	175
	Poids net			

A9 ZENITH

50 x 51 x 112 cm

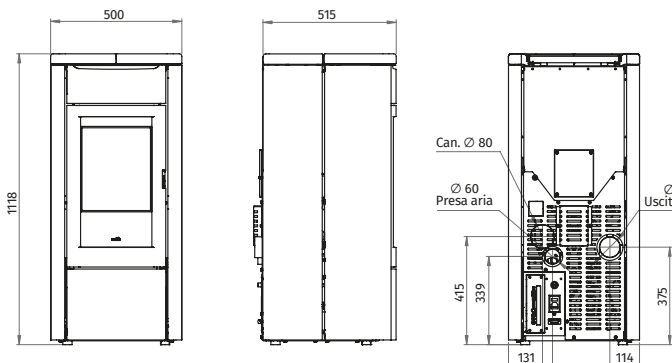

			V	C
Potenza termica nom.	Nominal heat output	kW	min 3,8	3,8
	Puissance thermique nom.		max 8,6	8,6
Consumo orario pellet	Pellet consumption	kg/h	min 0,9	0,9
	Consommation granulés		max 1,9	1,9
Rendimento	Yield	%	90,9	90,9
	Rendement			
Capacità serbatoio	Tank capacity	kg	19	19
	Capacité du réservoir			
Tubo uscita fumi	Smoke outlet pipe	Ø mm	80	80
	Tuyau de sortie des fumées			
Autonomia	Burn time	h	min 10	10
	Autonomie		max 22	22
Potenza elettrica inst.	Installed power	W	15	60
	Puissance électrique			
Peso netto	Net weight	kg	163	165
	Poids net			

A10 ZENITH PLUS

45° 50 x 51 x 112 cm

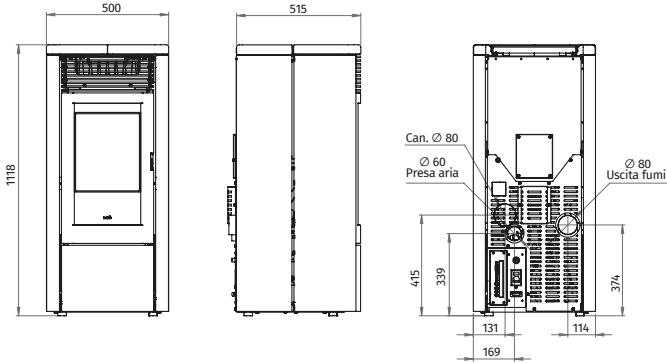

Potenza termica nom. Nominal heat output Puisance thermique nom.	kW	min max	3,8 9,5	3,8 9,5
Consumo orario pellet Pellet consumption Consumation granulés	kg/h	min max	0,9 2,2	0,9 2,2
Rendimento Yield Rendement	%		90,9	90,9
Capacità serbatoio Tank capacity Capacité du réservoir	kg		19	19
Tubo uscita fumi Smoke outlet pipe Tuyau de sortie des fumées	Ø mm		80	80
Autonomia Burn time Autonomie	h	min max	9 22	9 22
Potenza elettrica inst. Installed power Puisance électrique	W		15	60
Peso netto Net weight Poids net	kg		163	165

A8 QUADRA

45° 44 x 50 x 112 cm

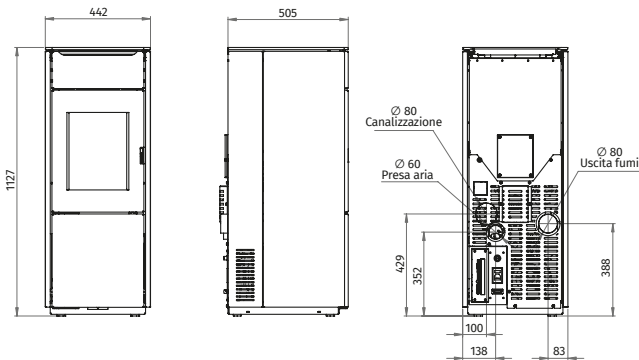

Potenza termica nom. Nominal heat output Puisance thermique nom.	kW	min max	3,8 7,8	3,8 7,8
Consumo orario pellet Pellet consumption Consumation granulés	kg/h	min max	0,9 1,8	0,9 1,8
Rendimento Yield Rendement	%		92,1	92,1
Capacità serbatoio Tank capacity Capacité du réservoir	kg		19	19
Tubo uscita fumi Smoke outlet pipe Tuyau de sortie des fumées	Ø mm		80	80
Autonomia Burn time Autonomie	h	min max	11 22	11 22
Potenza elettrica inst. Installed power Puisance électrique	W		15	60
Peso netto Net weight Poids net	kg		153	155

A8 QUADRA TOP

45° 44 x 56 x 112 cm

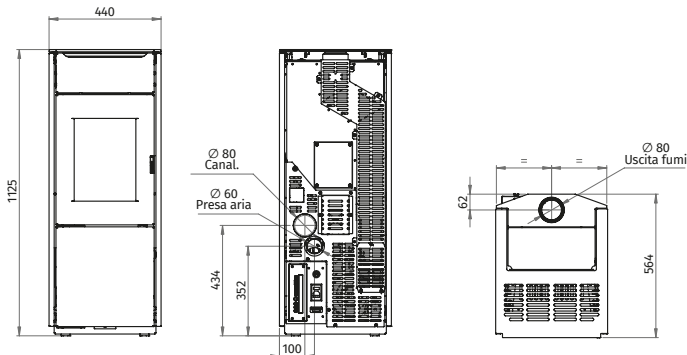

Potenza termica nom. Nominal heat output Puisance thermique nom.	kW	min max	3,8 7,8	3,8 7,8
Consumo orario pellet Pellet consumption Consumation granulés	kg/h	min max	0,9 1,8	0,9 1,8
Rendimento Yield Rendement	%		92,1	92,1
Capacità serbatoio Tank capacity Capacité du réservoir	kg		15	15
Tubo uscita fumi Smoke outlet pipe Tuyau de sortie des fumées	Ø mm		80	80
Autonomia Burn time Autonomie	h	min max	9 17	9 17
Potenza elettrica inst. Installed power Puisance électrique	W		15	60
Peso netto Net weight Poids net	kg		153	155

A10 QUADRA PLUS

44 x 50 x 112 cm

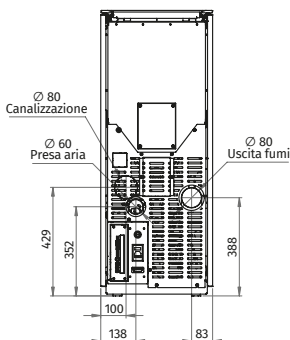
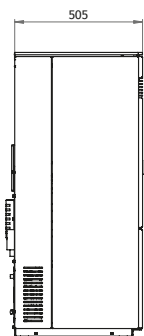
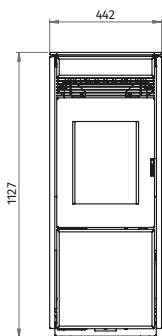

Potenza termica nom. Nominal heat output Puissance thermique nom.	kW	min max	3,8 9,5	3,8 9,5
Consumo orario pellet Pellet consumption Consommation granulés	kg/h	min max	0,9 2,1	0,9 2,1
Rendimento Yield Rendement	%		90,9	90,9
Capacità serbatoio Tank capacity Capacité du réservoir	kg		19	19
Tubo uscita fumi Smoke outlet pipe Tuyau de sortie des fumées	Ø		80	80
Autonomia Burn time Autonomie	h	min max	9 22	9 22
Potenza elettrica inst. Installed power Puissance électrique	W		15	60
Peso netto Net weight Poids net	kg		153	155

A10 QUADRA PLUS TOP

44 x 56 x 112 cm

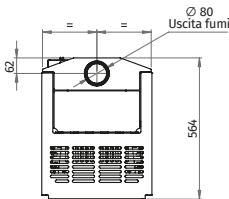
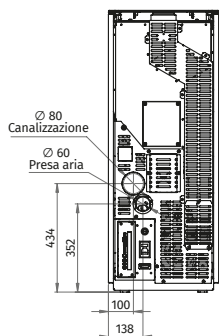
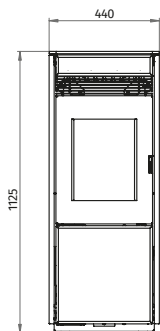

Potenza termica nom. Nominal heat output Puissance thermique nom.	kW	min max	3,8 9,5	3,8 9,5
Consumo orario pellet Pellet consumption Consommation granulés	kg/h	min max	0,9 2,1	0,9 2,1
Rendimento Yield Rendement	%		90,9	90,9
Capacità serbatoio Tank capacity Capacité du réservoir	kg		15	15
Tubo uscita fumi Smoke outlet pipe Tuyau de sortie des fumées	Ø		80	80
Autonomia Burn time Autonomie	h	min max	7 17	7 17
Potenza elettrica inst. Installed power Puissance électrique	W		15	60
Peso netto Net weight Poids net	kg		153	155

A9 CLASSIC

53 x 52 x 118 cm

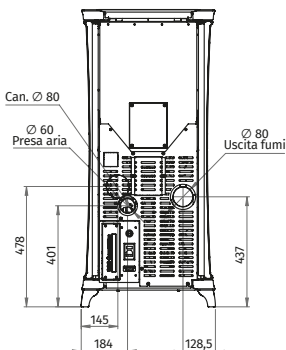
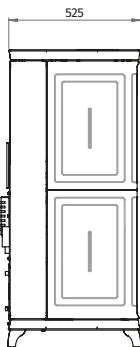
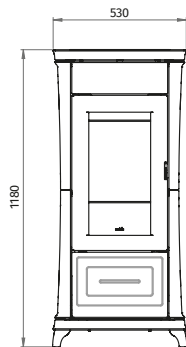

Potenza termica nom. Nominal heat output Puissance thermique nom.	kW	min max	3,8 8,6	3,8 8,6
Consumo orario pellet Pellet consumption Consommation granulés	kg/h	min max	0,9 2,0	0,9 2,0
Rendimento Yield Rendement	%		90,9	90,9
Capacità serbatoio Tank capacity Capacité du réservoir	kg		19	19
Tubo uscita fumi Smoke outlet pipe Tuyau de sortie des fumées	Ø		80	80
Autonomia Burn time Autonomie	h	min max	10 22	10 22
Potenza elettrica inst. Installed power Puissance électrique	W		15	60
Peso netto Net weight Poids net	kg		185	187

A10 CLASSIC PLUS

53 x 52 x 118 cm

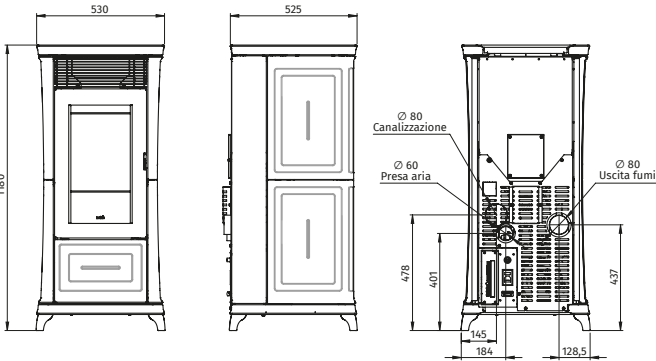

Potenza termica nom. Nominal heat output	kW	min 3,8	max 3,8
Puissance thermique nom.		min 9,5	max 9,5
Consumo orario pellet Pellet consumption	kg/h	min 0,9	max 0,9
Consommation granulés		min 2,2	max 2,2
Rendimento Yield	%	90,9	90,9
Capacità serbatoio Tank capacity	kg	19	19
Capacité du réservoir			
Tubo uscita fumi Smoke outlet pipe	Ø	80	80
Tuyau de sortie des fumées			
Autonomia Burn time	h	min 9	max 9
Autonomie		min 22	max 22
Potenza elettrica inst. Installed power	W	15	60
Puissance électrique			
Peso netto Net weight	kg	185	187
Poids net			

A8 | A10 STYLE

56 x 50 x 112 cm

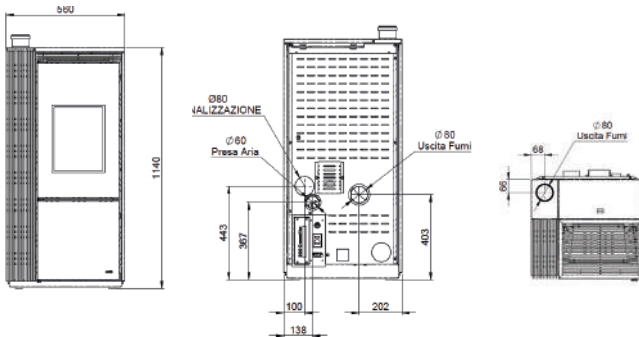

Potenza termica nom. Nominal heat output	kW	min 3,8	max 3,8
Puissance thermique nom.		min 7,8	max 9,5
Consumo orario pellet Pellet consumption	kg/h	min 0,9	max 0,9
Consommation granulés		min 1,8	max 2,2
Rendimento Yield	%	92,1	90,9
Capacità serbatoio Tank capacity	kg	19	19
Capacité du réservoir			
Tubo uscita fumi Smoke outlet pipe	Ø	80	80
Tuyau de sortie des fumées			
Autonomia Burn time	h	min 11	max 9
Autonomie		min 22	max 22
Potenza elettrica inst. Installed power	W	15	15
Puissance électrique		60	60
Peso netto Net weight	kg	180	180
Poids net			

A10 LIGHT

76 x 42 x 112 cm

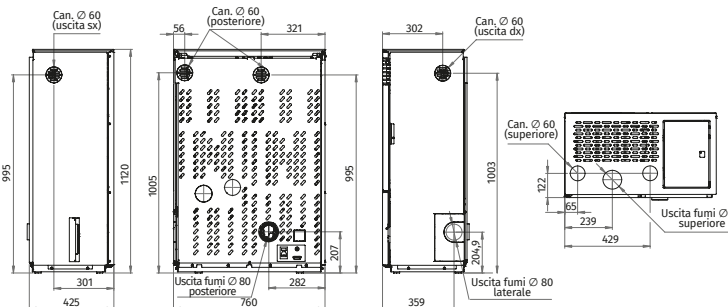

Potenza termica nom. Nominal heat output nom.	kW	min 3,8	max 9,5
Puissance thermique nom.		min 3,8	max 9,5
Consumo orario pellet Pellet consumption	kg/h	min 0,9	max 2,2
Consommation granulés		min 0,9	max 2,2
Rendimento Yield	%	90,9	
Capacità serbatoio Tank capacity	kg	35	
Capacité du réservoir			
Tubo uscita fumi Smoke outlet pipe	Ø	80	
Tuyau de sortie des fumées			
Autonomia Burn time	h	min 16	max 40
Autonomie		min 16	max 40
Potenza elettrica inst. Installed power	W	60	
Puissance électrique			
Peso netto Net weight	kg	210	
Poids net			

A10 LIGHT 2020

76 x 42 x 112 cm

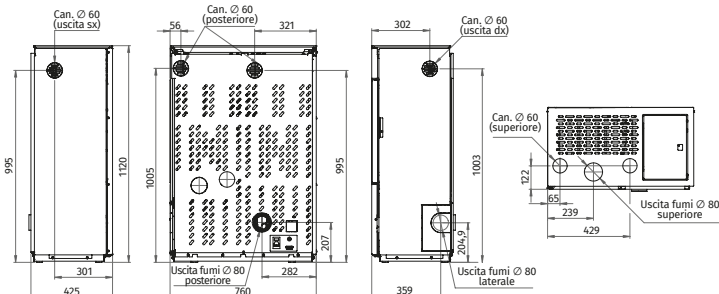

Potenza termica nom. Nominal heat output Puissance thermique nom.	kW	min max	3,8 9,5
Consumo orario pellet Pellet consumption Consommation granulés	kg/h	min max	0,9 2,2
Rendimento Yield Rendement	%		90,9
Capacità serbatoio Tank capacity Capacité du réservoir	kg		35
Tubo uscita fumi Smoke outlet pipe Tuyau de sortie des fumées	Ø		80
Autonomia Burn time Autonomie	h	min max	16 40
Potenza elettrica inst. Installed power Puissance électrique	W		60
Peso netto Net weight Poids net	kg		210

LISA 7|10

45 x 54 x 107 cm

7 10

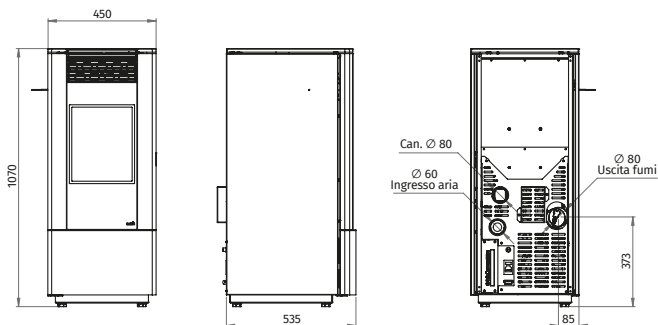

Potenza termica nom. Nominal heat output Puissance thermique nom.	kW	min max	3,4 7,0 3,4 9,3
Consumo orario pellet Pellet consumption Consommation granulés	kg/h	min max	0,8 0,8 1,6 2,2
Rendimento Yield Rendement	%		90,6 89,6
Capacità serbatoio Tank capacity Capacité du réservoir	kg		16 16
Tubo uscita fumi Smoke outlet pipe Tuyau de sortie des fumées	Ø		80 80
Autonomia Burn time Autonomie	h	min max	10 7 20 20
Potenza elettrica inst. Installed power Puissance électrique	W		55 55 65 65
Peso netto Net weight Poids net	kg		120 120

ELENA 12

71 x 36 x 119 cm

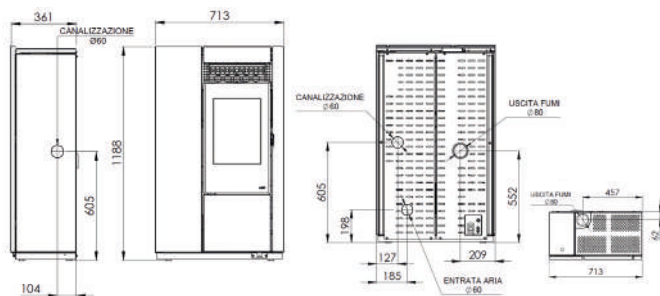

Potenza termica nom. Nominal heat output Puissance thermique nom.	kW	min max	4,6 11,2 4,6 11,2
Consumo orario pellet Pellet consumption Consommation granulés	kg/h	min max	1,1 1,1 2,6 2,6
Rendimento Yield Rendement	%		89,2 89,2
Capacità serbatoio Tank capacity Capacité du réservoir	kg		23 23
Tubo uscita fumi Smoke outlet pipe Tuyau de sortie des fumées	Ø		80 80
Autonomia Burn time Autonomie	h	min max	9 9 21 21
Potenza elettrica inst. Installed power Puissance électrique	W		60 65
Peso netto Net weight Poids net	kg		130 130

A11 | A13 ROUND

cm 53 x 54 x 125

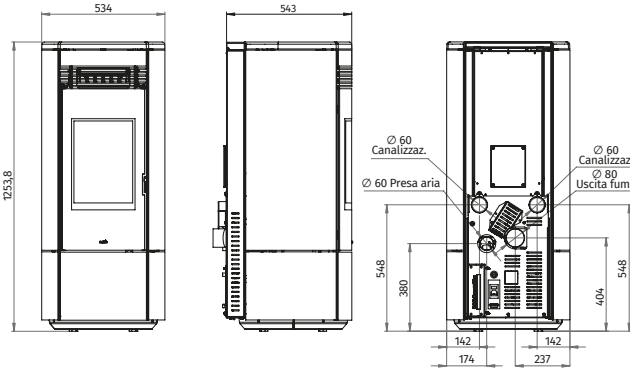

A11 A13
VC VC

Potenza termica nom. Nominal heat output	kW min	4,6	4,6
Puissance thermique nom.	max	10,2	11,8
Consumo orario pellet Pellet consumption	kg/h min	1,0	1,1
Consommation granulés	max	2,3	2,8
Rendimento Yield	%	92,5	91,2
Rendement			
Capacità serbatoio Tank capacity	kg	20	20
Capacité du réservoir			
Tubo uscita fumi Smoke outlet pipe	Ø	80	80
Tuyau de sortie des fumées	mm		
Autonomia Burn time	h min	9	7
Autonomie	max	20	19
Potenza elettrica inst. Installed power	W	35	35
Puissance électrique		110	110
Peso netto Net weight	kg	160	160
Poids net			

A11 | A13 ROUND TOP

cm 53 x 57 x 125

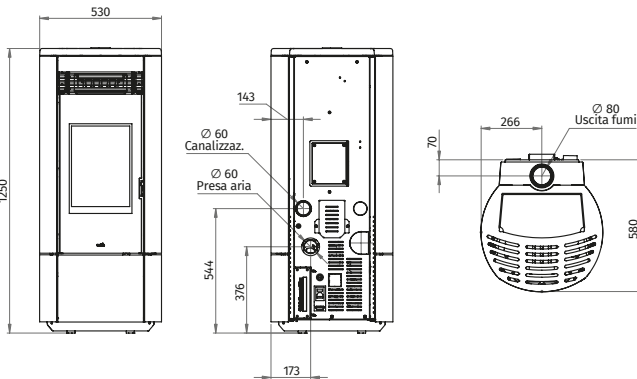

A11 A13
VC VC

Potenza termica nom. Nominal heat output	kW min	4,6	4,6
Puissance thermique nom.	max	10,2	11,8
Consumo orario pellet Pellet consumption	kg/h min	1,0	1,1
Consommation granulés	max	2,3	2,8
Rendimento Yield	%	92,5	91,2
Rendement			
Capacità serbatoio Tank capacity	kg	17	17
Capacité du réservoir			
Tubo uscita fumi Smoke outlet pipe	Ø	80	80
Tuyau de sortie des fumées	mm		
Autonomia Burn time	h min	7	7
Autonomie	max	17	17
Potenza elettrica inst. Installed power	W	35	35
Puissance électrique		110	110
Peso netto Net weight	kg	183	183
Poids net			

A11 | A13 ROUND GLASS

cm 53 x 54 x 125

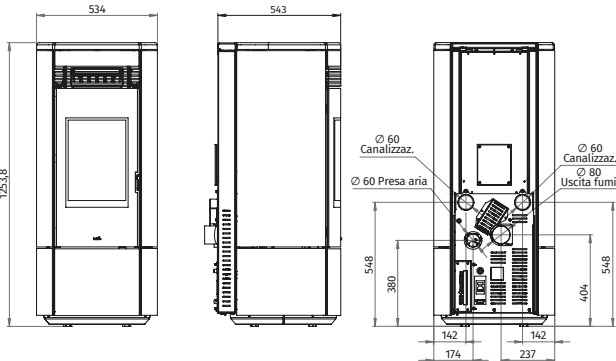

A11 A13
VC VC

Potenza termica nom. Nominal heat output	kW min	4,6	4,6
Puissance thermique nom.	max	10,2	11,8
Consumo orario pellet Pellet consumption	kg/h min	1,0	1,1
Consommation granulés	max	2,3	2,8
Rendimento Yield	%	92,5	91,2
Rendement			
Capacità serbatoio Tank capacity	kg	20	20
Capacité du réservoir			
Tubo uscita fumi Smoke outlet pipe	Ø	80	80
Tuyau de sortie des fumées	mm		
Autonomia Burn time	h min	9	7
Autonomie	max	20	19
Potenza elettrica inst. Installed power	W	35	35
Puissance électrique		110	110
Peso netto Net weight	kg	160	160
Poids net			

A11 | A13 ROUND GLASS TOP 53 x 57 x 125 cm

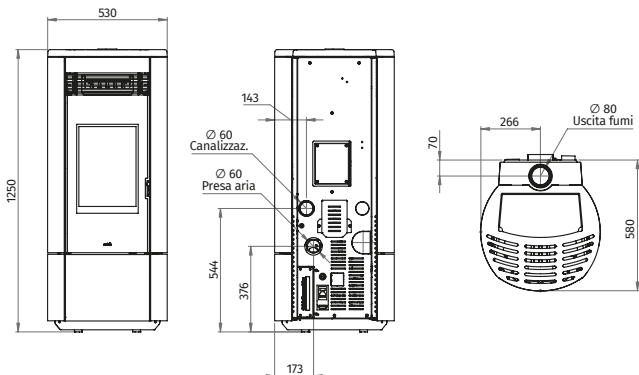

		A11	A13
Potenza termica nom. Nominal heat output Puisance thermique nom.	kW min	4,6	4,6
	max	10,2	11,8
Consumo orario pellet Pellet consumption Consummation granulés	kg/h min	1,0	1,1
	max	2,3	2,8
Rendimento Yield Rendement	%	92,5	91,2
Capacità serbatoio Tank capacity Capacité du réservoir	kg	17	17
Tubo uscita fumi Smoke outlet pipe Tuyau de sortie des fumées	Ø mm	80	80
Autonomia Burn time Autonomie	h min	7	6
	max	17	17
Potenza elettrica inst. Installed power Puisance électrique	W	35	35
		110	110
Peso netto Net weight Poids net	kg	183	183

A11 | A13 ZENITH

52 x 54 x 121 cm

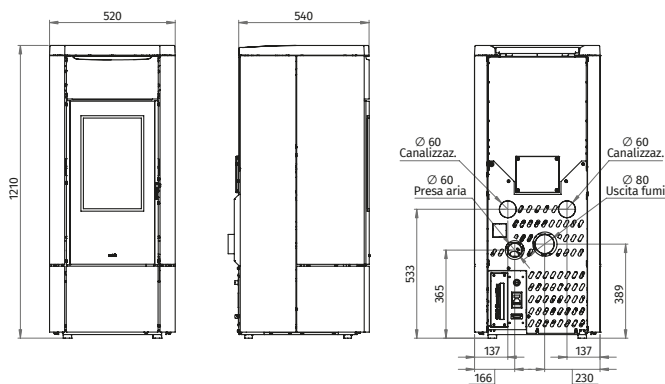

		A11	A13
Potenza termica nom. Nominal heat output Puisance thermique nom.	kW min	4,6	4,6
	max	10,2	11,8
Consumo orario pellet Pellet consumption Consummation granulés	kg/h min	1,0	1,1
	max	2,3	2,8
Rendimento Yield Rendement	%	92,5	91,2
Capacità serbatoio Tank capacity Capacité du réservoir	kg	22	22
Tubo uscita fumi Smoke outlet pipe Tuyau de sortie des fumées	Ø mm	80	80
Autonomia Burn time Autonomie	h min	10	8
	max	22	22
Potenza elettrica inst. Installed power Puisance électrique	W	35	35
		110	110
Peso netto Net weight Poids net	kg	183	183

A11 | A13 ZENITH PLUS

52 x 54 x 121 cm

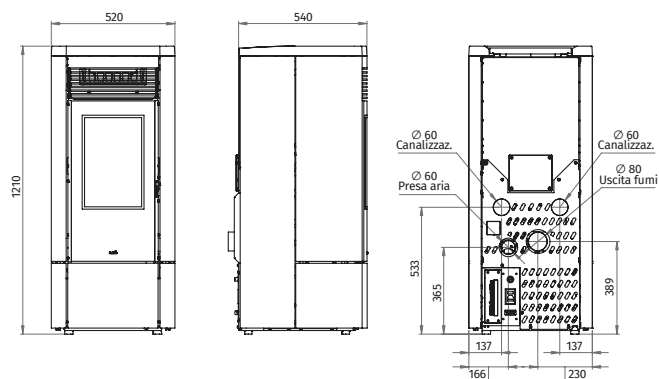

		A11	A13
Potenza termica nom. Nominal heat output Puisance thermique nom.	kW min	4,6	4,6
	max	10,2	11,8
Consumo orario pellet Pellet consumption Consummation granulés	kg/h min	1,0	1,1
	max	2,3	2,8
Rendimento Yield Rendement	%	92,5	91,2
Capacità serbatoio Tank capacity Capacité du réservoir	kg	22	22
Tubo uscita fumi Smoke outlet pipe Tuyau de sortie des fumées	Ø mm	80	80
Autonomia Burn time Autonomie	h min	10	8
	max	22	22
Potenza elettrica inst. Installed power Puisance électrique	W	35	35
		110	110
Peso netto Net weight Poids net	kg	183	183

B10V ULISSE

69 x 49 x 50 cm

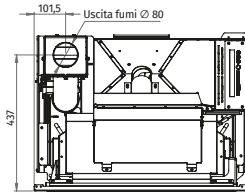
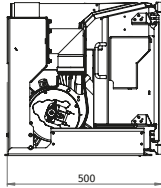
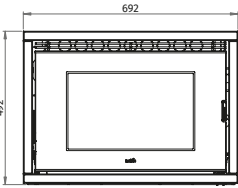

Potenza termica nom. Nominal heat output Puissance thermique nom.	kW	min max	4,5 9,0
Consumo orario pellet Pellet consuption Consommation granulés	kg/h	min max	1,0 2,0
Rendimento Yield Rendement	%		90,8
Capacità serbatoio Tank capacity Capacité du réservoir	kg		14
Tubo uscita fumi Smoke outlet pipe Tuyau de sortie des fumées	Ø		80
Autonomia Burn time Autonomie	h	min max	7 14
Potenza elettrica inst. Installed power Puissance électrique	W		90
Peso netto Net weight Poids net	kg		95

B10C ULISSE

69 x 59 x 58 cm

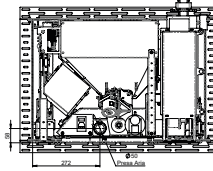
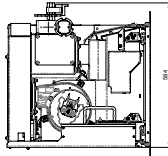
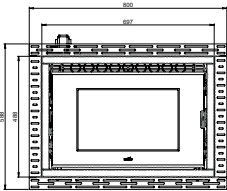

Potenza termica nom. Nominal heat output Puissance thermique nom.	kW	min max	4,5 9,0
Consumo orario pellet Pellet consuption Consommation granulés	kg/h	min max	1,0 2,0
Rendimento Yield Rendement	%		90,8
Capacità serbatoio Tank capacity Capacité du réservoir	kg		14
Tubo uscita fumi Smoke outlet pipe Tuyau de sortie des fumées	Ø		80
Autonomia Burn time Autonomie	h	min max	7 14
Potenza elettrica inst. Installed power Puissance électrique	W		90
Peso netto Net weight Poids net	kg		95

B13 ULISSE

83 x 62 x 120 cm

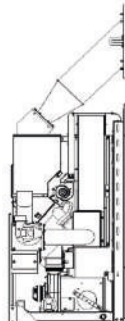
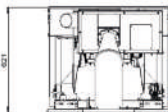
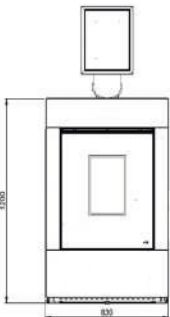

Potenza termica nom. Nominal heat output Puissance thermique nom.	kW	min max	4,6 11,2
Consumo orario pellet Pellet consuption Consommation granulés	kg/h	min max	1,1 2,6
Rendimento Yield Rendement	%		89,2
Capacità serbatoio Tank capacity Capacité du réservoir	kg		23
Tubo uscita fumi Smoke outlet pipe Tuyau de sortie des fumées	Ø		80
Autonomia Burn time Autonomie	h	min max	9 21
Potenza elettrica inst. Installed power Puissance électrique	W		60/65
Peso netto Net weight Poids net	kg		130

HB14 | 17 ULISSE HYDRO

83 x 62 x 120 cm
88 x 107 x 76 cm (ext.)

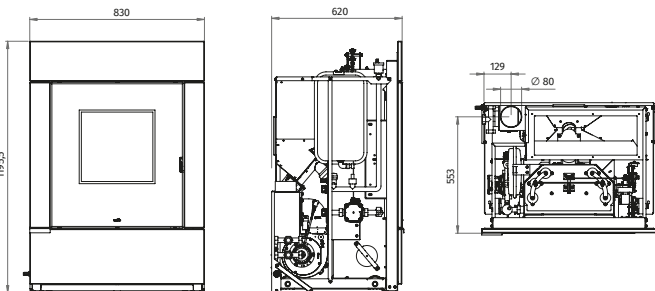

		min	max	HB14	h17
Potenza termica nom. Nominal heat output Puisance thermique nom.	kW	min	max	8,4	8,4
				17,8	19,8
Consumo orario pellet Pellet consumption Consommation granulés	kg/h	min	max	1,9	1,9
				3,4	4,5
Rendimento Yield Rendement	%			94,2	93,5
Capacità serbatoio Tank capacity Capacité du réservoir	kg			28	28
Tubo uscita fumi Smoke outlet pipe Tuyau de sortie des fumées	Ø mm			80	80
Autonomia Burn time Autonomie	h	min	max	7	6
				15	15
Potenza elettrica inst. Installed power Puisance électrique	W			16	19
Peso netto Net weight Poids net	kg			220	220

H10/12 SHAPE

53 x 60 x 113 cm

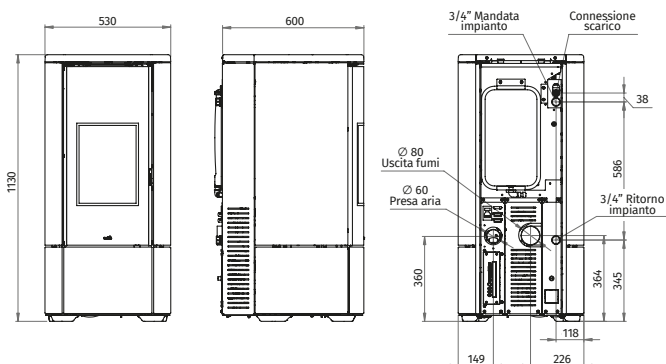

		min	max	H10	H12
Potenza termica nom. Nominal heat output Puisance thermique nom.	kW	min	max	6,4	6,4
				13,3	15,5
Consumo orario pellet Pellet consumption Consommation granulés	kg/h	min	max	1,4	1,4
				2,9	3,4
Rendimento Yield Rendement	%			93,9	92,6
Capacità serbatoio Tank capacity Capacité du réservoir	kg			20	20
Tubo uscita fumi Smoke outlet pipe Tuyau de sortie des fumées	Ø mm			80	80
Autonomia Burn time Autonomie	h	min	max	7	6
				15	15
Potenza elettrica inst. Installed power Puisance électrique	W			16	20
Peso netto Net weight Poids net	kg			165	165

H10/12 SHAPE GLASS

53 x 60 x 113 cm

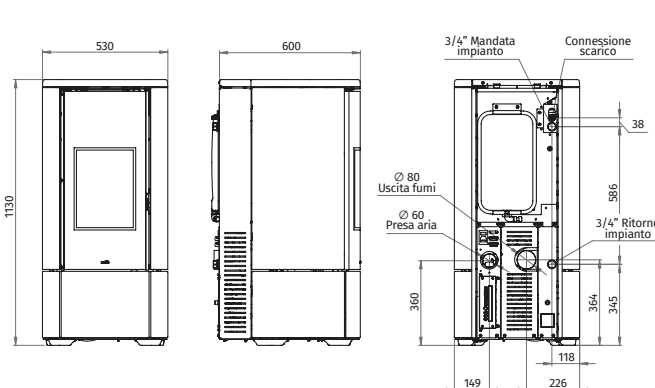

		min	max	H10	H12
Potenza termica nom. Nominal heat output Puisance thermique nom.	kW	min	max	6,4	6,4
				13,3	15,5
Consumo orario pellet Pellet consumption Consommation granulés	kg/h	min	max	1,4	1,4
				2,9	3,4
Rendimento Yield Rendement	%			93,9	92,6
Capacità serbatoio Tank capacity Capacité du réservoir	kg			20	20
Tubo uscita fumi Smoke outlet pipe Tuyau de sortie des fumées	Ø mm			80	80
Autonomia Burn time Autonomie	h	min	max	7	6
				15	15
Potenza elettrica inst. Installed power Puisance électrique	W			16	20
Peso netto Net weight Poids net	kg			165	165

H14 SHAPE

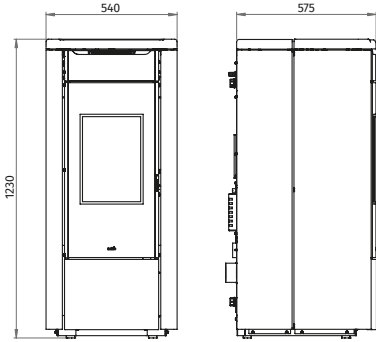

54 x 57 x 123 cm

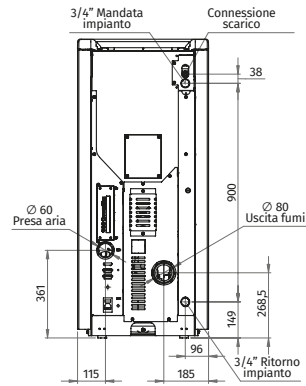

Potenza termica nom. Nominal heat output Puissance thermique nom.	kW	min max	8,4 17,8
Consumo orario pellet Pellet consumption Consommation granulés	kg/h	min max	1,9 4
Rendimento Yield Rendement	%		94,2
Capacità serbatoio Tank capacity Capacité du réservoir	kg		21
Tubo uscita fumi Smoke outlet pipe Tuyau de sortie des fumées	Ø mm		80
Autonomia Burn time Autonomie	h	min max	5 11
Potenza elettrica inst. Installed power Puissance électrique	W		16
Peso netto Net weight Poids net	kg		185

H14 | H17 SHAPE ROUND

54 x 57 x 123 cm



H14 H17

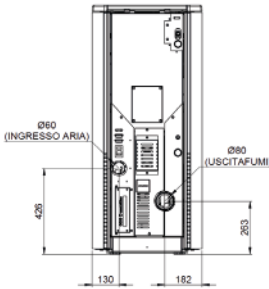
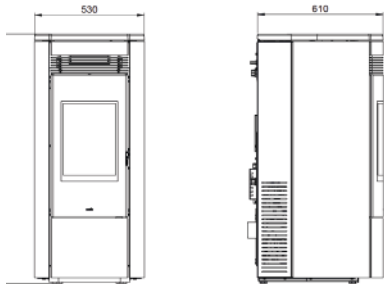

Potenza termica nom. Nominal heat output Puissance thermique nom.	kW	min max	8,4 17,8	8,4 19,8
Consumo orario pellet Pellet consumption Consommation granulés	kg/h	min max	1,9 4	1,9 4,5
Rendimento Yield Rendement	%		94,2	93,5
Capacità serbatoio Tank capacity Capacité du réservoir	kg		22	22
Tubo uscita fumi Smoke outlet pipe Tuyau de sortie des fumées	Ø mm		80	80
Autonomia Burn time Autonomie	h	min max	6 12	5 12
Potenza elettrica inst. Installed power Puissance électrique	W		16	19
Peso netto Net weight Poids net	kg		185	220

H17 LIGHT

94 x 35 x 112 cm

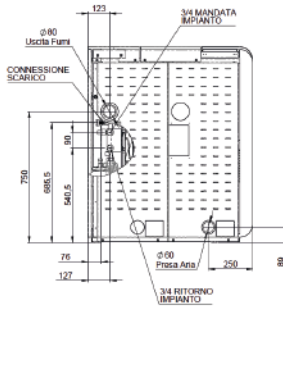
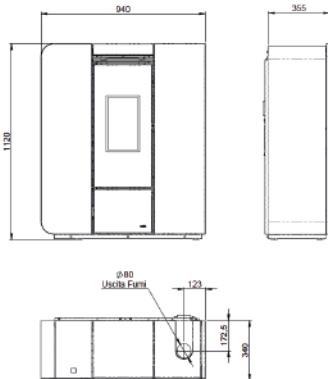

Potenza termica nom. Nominal heat output Puissance thermique nom.	kW	min max	7,9 20
Consumo orario pellet Pellet consumption Consommation granulés	kg/h	min max	1,8 4,4
Rendimento Yield Rendement	%		93,3
Capacità serbatoio Tank capacity Capacité du réservoir	kg		25
Tubo uscita fumi Smoke outlet pipe Tuyau de sortie des fumées	Ø mm		80
Autonomia Burn time Autonomie	h	min max	6 15
Potenza elettrica inst. Installed power Puissance électrique	W		23
Peso netto Net weight Poids net	kg		210

H17 SHAPE

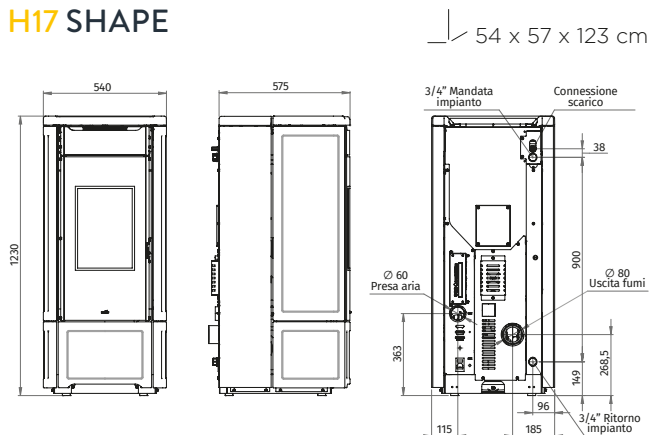

Potenza termica nom. Nominal heat output Puisissance thermique nom.	kW	min max	8,4 19,8
Consumo orario pellet Pellet consumption Consommation granulés	kg/h	min max	1,8 5
Rendimento Rendement	%		93,5
Capacità serbatoio Tank capacity Capacité du réservoir	kg		21
Tubo uscita fumi Smoke outlet pipe Tuyau de sortie des fumées	Ø		80
Autonomia Burn time Autonomie	h	min max	5 11
Potenza elettrica inst. Installed power Puisissance électrique	W		19
Peso netto Net weight	kg		220

H17 SHAPE STEEL

54 x 57 x 123 cm

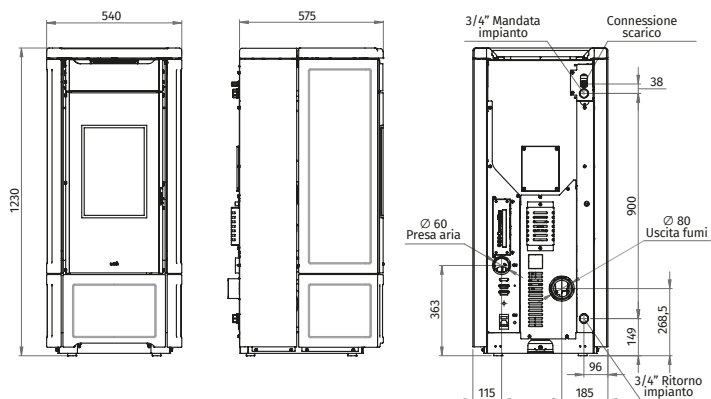

Potenza termica nom. Nominal heat output Puisissance thermique nom.	kW	min max	8,4 19,8
Consumo orario pellet Pellet consumption Consommation granulés	kg/h	min max	1,9 4,5
Rendimento Rendement	%		93,5
Capacità serbatoio Tank capacity Capacité du réservoir	kg		21
Tubo uscita fumi Smoke outlet pipe Tuyau de sortie des fumées	Ø		80
Autonomia Burn time Autonomie	h	min max	5 11
Potenza elettrica inst. Installed power Puisissance électrique	W		19
Peso netto Net weight	kg		220

H20 SHAPE

57 x 66 x 130 cm

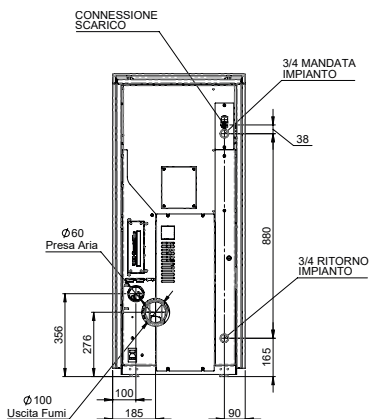

Potenza termica nom. Nominal heat output Puisissance thermique nom.	kW	min max	10,2 22,2
Consumo orario pellet Pellet consumption Consommation granulés	kg/h	min max	2,3 4,9
Rendimento Rendement	%		93,6
Capacità serbatoio Tank capacity Capacité du réservoir	kg		37
Tubo uscita fumi Smoke outlet pipe Tuyau de sortie des fumées	Ø		100
Autonomia Burn time Autonomie	h	min max	7,5 16
Potenza elettrica inst. Installed power Puisissance électrique	W		32
Peso netto Net weight	kg		260

H25 SHAPE

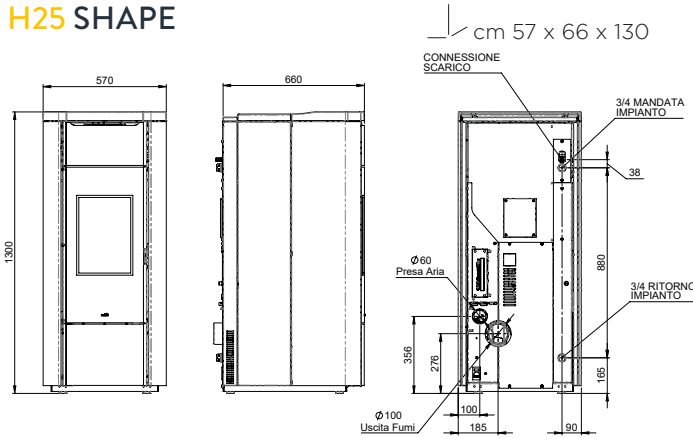

Potenza termica nom. Nominal heat output Puissance thermique nom.	kW	min max	10,2 27,7
Consumo orario pellet Pellet consumption Consommation granulés	kg/h	min max	2,3 6,2
Rendimento Yield Rendement	%		92,3
Capacità serbatoio Tank capacity Capacité du réservoir	kg		37
Tubo uscita fumi Smoke outlet pipe Tuyau de sortie des fumées	Ø		100
Autonomia Burn time Autonomie	h	min max	6 16
Potenza elettrica inst. Installed power Puissance électrique	W		37
Peso netto Net weight Poids net	kg		273

POLYGON 25*

105 x 62 x 140 cm

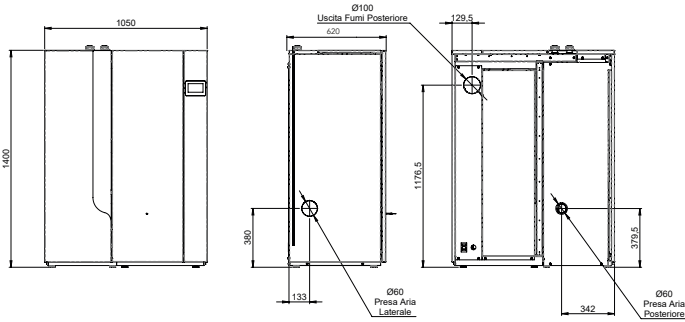

Potenza all'acqua Energy transferred to water Puissance transmis à l'eau	kW	min max	7,2 24,7
Capacità acqua Water capacity Capacité eau	l		80
Rendimento Yield Rendement	%		92
Capacità serbatoio Tank capacity Capacité du réservoir	kg		75
Polveri Fine dust Particules fines	Mg/ Nm3		2,9
Nox	Mg/ Nm3		111
CO	Mg/ Nm3		15
Peso netto Net weight Poids net	kg		350

POLYGON 28*

105 x 62 x 140 cm

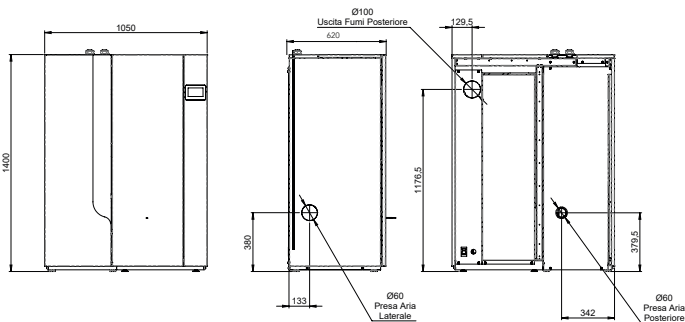

Potenza all'acqua Energy transferred to water Puissance transmis à l'eau	kW	min max	7,2 27
Capacità acqua Water capacity Capacité eau	l		85
Rendimento Yield Rendement	%		92,2
Capacità serbatoio Tank capacity Capacité du réservoir	kg		80
Polveri Fine dust Particules fines	Mg/ Nm3		5,3
Nox	Mg/ Nm3		113
CO	Mg/ Nm3		15
Peso netto Net weight Poids net	kg		350

POLYGON 32

100 x 62 x 140 cm

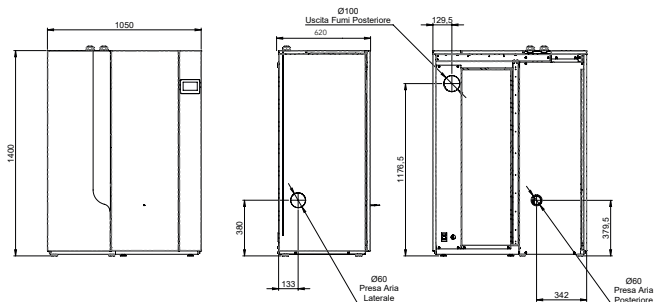

Potenza all'acqua Energy transferred to water Puissance transmis à l'eau	kW	min max	7.2 29
Capacità acqua Water capacity Capacité eau	l		80
Rendimento Yield Rendement	%		92,2
Capacità serbatoio Tank capacity Capacité du réservoir	kg		75
Polveri Fine dust Particules fines	Mg/ Nm ³		7,8
Nox	Mg/ Nm ³		115
CO	Mg/ Nm ³		17
Peso netto Net weight Poids net	kg		350

FLAT 100*

52 x 54 x 121 cm

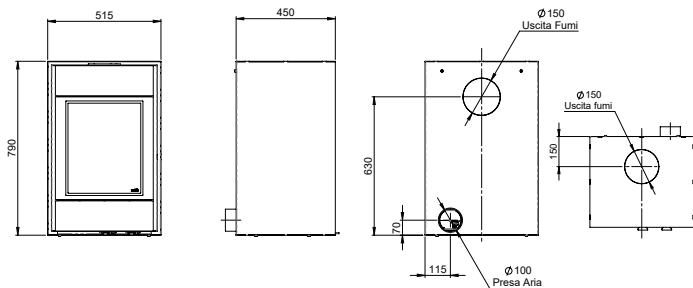

100

Tubo uscita fumi Smoke outlet pipe Tuyau de sortie des fumées	Ø mm	150	150
Peso netto Net weight Poids net	kg	145	145

FLAT 300-330*

52 x 54 x 121 cm

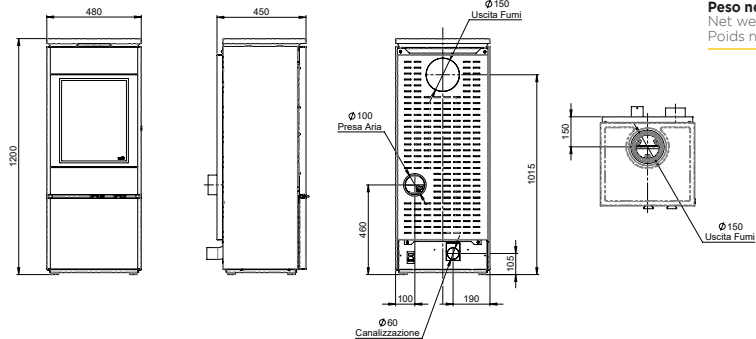

300-330

Tubo uscita fumi Smoke outlet pipe Tuyau de sortie des fumées	Ø mm	150	150
Peso netto Net weight Poids net	kg	165	165

FLAT 500-550*

52 x 54 x 121 cm

500-550

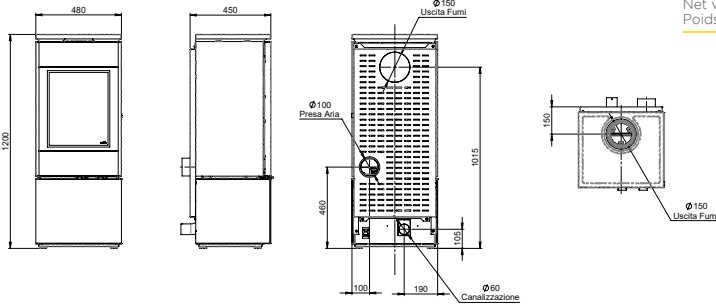

Tubo uscita fumi Smoke outlet pipe Tuyau de sortie des fumées	Ø mm	150	150
Peso netto Net weight Poids net	kg	165	165

FLAT 700-770*

52 x 54 x 121 cm

700-770

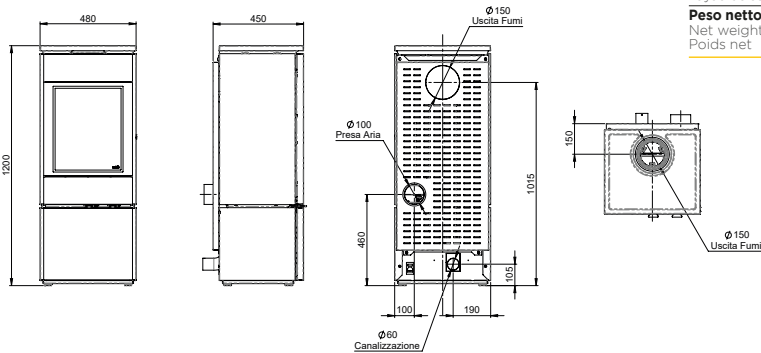

Tubo uscita fumi Smoke outlet pipe Tuyau de sortie des fumées	Ø mm	150	150
Peso netto Net weight Poids net	kg	165	165

ZENITH 400-440*

cm 52 x 54 x 121

400-440

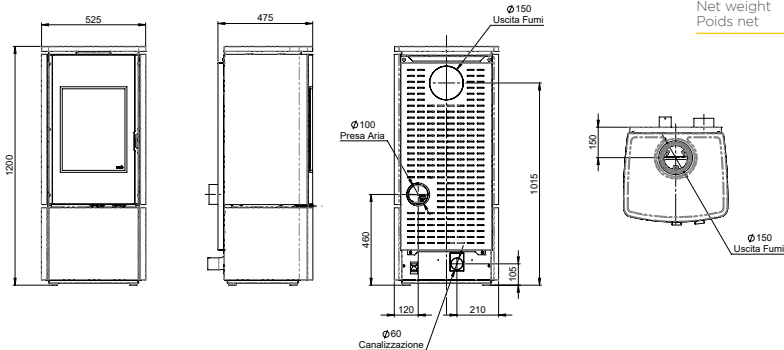

Tubo uscita fumi Smoke outlet pipe Tuyau de sortie des fumées	Ø mm	150	150
Peso netto Net weight Poids net	kg	165	165

ZENITH 600-660*

cm 52 x 54 x 121

600-660

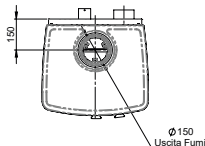
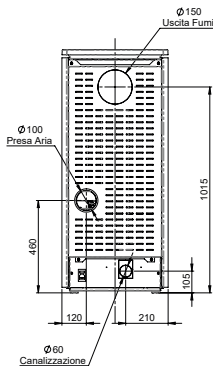
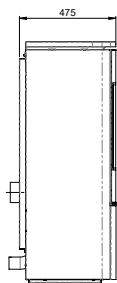
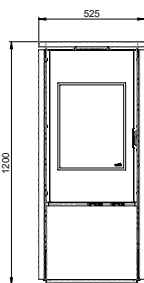

Tubo uscita fumi Smoke outlet pipe Tuyau de sortie des fumées	Ø mm	150	150
Peso netto Net weight Poids net	kg	165	165

ZENITH 800-880*

cm 52 x 54 x 121

800-880

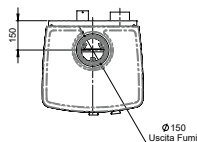
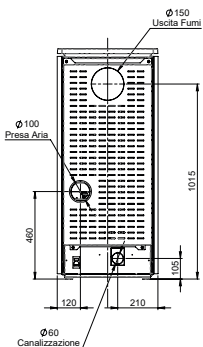
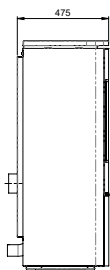
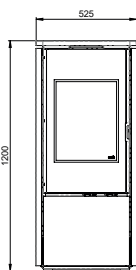

Tubo uscita fumi Smoke outlet pipe Tuyau de sortie des fumées	Ø mm	150	150
Peso netto Net weight Poids net	kg	165	165

CLASSIC 200-220*

cm 52 x 54 x 121

800-880

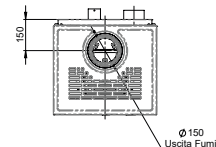
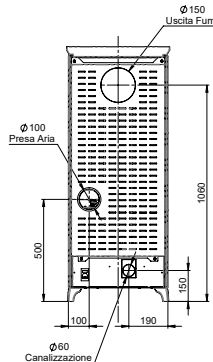
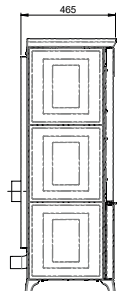
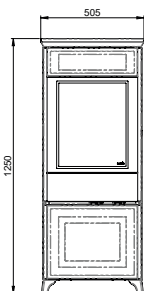

Tubo uscita fumi Smoke outlet pipe Tuyau de sortie des fumées	Ø mm	150	150
Peso netto Net weight Poids net	kg	165	165

Tutti i dati tecnici e traduzioni raccolte in questo catalogo sono da ritenersi indicativi. Inoltre, i valori di rese, m³, kW, sono riferiti a prove di laboratorio e potrebbero variare se effettuate in altri locali.
Nel continuo miglioramento dei suoi prodotti, Nobis si riserva di apportare in qualsiasi momento e senza preavviso modifiche tecniche ed estetiche.
I colori sono da considerarsi puramente indicativi.

All of the technical informations and traslations provided in this catalogue are purely indicative and cannot be deemed to the definitive. Moreover, the yields, m³, and kW provided always refer to laboratory tests and may vary if carried out at other locations.
The company reserves the right to make changes at any time, without prior warning
The colours provided are to be considered purely indicative.

Toutes les informations techniques et les traductions de ce catalogue sont fournies à titre exclusivement indicatif. En outre, les rendements, m³ et kW se réfèrent dans tous les cas aux essais de laboratoire et peuvent donc varier selon les différentes installations.
La société se réserve le droit d'apporter des modifications à tout moment et sans préavis.
Les couleurs sont uniquement indicatives.

IT | EN | FR



via Palazzolo 11
25037 Pontoglio (BS)

www.nobisfire.it

nobis
YOUR STOVE, OUR PASSION